

Studio Stove 14

Studio Stove—clean air approved wood burner Installation instructions

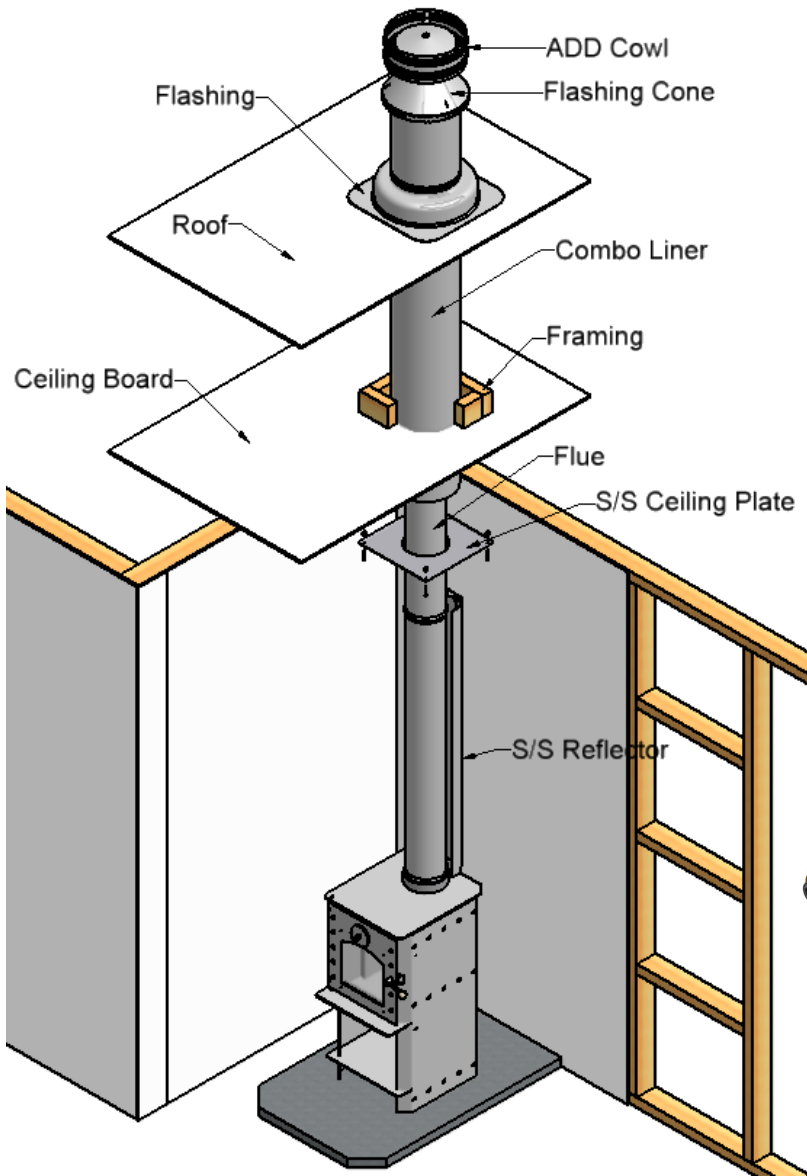

The Warmington “Airback”

The Warmington Studio Stove is fitted with an “Airback”. The “Airback” is designed to be left in the firebox and act as a heat exchanger. It makes the fire-place burn more efficiently and cleaner. It does not change how you use the fire or how it is installed, but the improved performance allows the fire to be installed in sub 0.7 g/kg areas like Otago, Canterbury, Nelson and Alexandra.

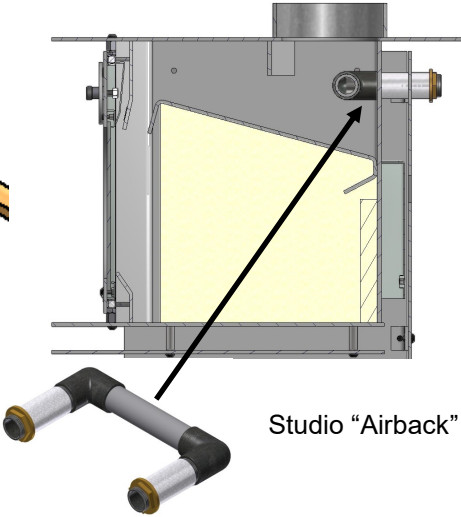

NOTE A rural fire that can burn for longer periods can be ordered, but contact your local council for installation and clean air compliance requirements.

Visit www.warmington.co.nz for Specs, DWG's and PDF uploads of Fires

Fire, flue system and instructions to comply with AS/NZS 2918:2001

Keep these Instructions for future reference. Ensure that you have the correct and current installation details for the Warmington fire

Installation

The Warmington unit is to be installed by a certified Warmington installer or an approved NZHHA installation technician. See www.homeheat.co.nz/members for a certified NZHHA SFAIT installer in your area.

CLEARANCES TO COMBUSTIBLE SURFACES UNLESS STATED OTHERWISE

IMPORTANT

Read all the instructions carefully before commencing the installation. Failure to follow these instructions may result in a fire hazard and will void the warranty

Due to continued product improvement, Warmington Ind LTD reserves the right to change product specifications without prior notification.



BURN ONLY SOFTWOOD-TESTED TO AS/NZS 4013:2014
Fuel should be loaded front to back or left to right.

MODEL:	Warmington Studio	Stove 14	Stove 14 Wet
ECan Authorisation Number		160215	160362
Average Space Heating Efficiency Burning Softwood		71%	61%
Overall Average Efficiency Burning Softwood		71%	67%
Average Particulate Emission Factor Burning Softwood		0.66 g/kg 46 mg/MJ	0.55 g/kg 40 mg/MJ
Maximum Average Heat Output Burning Softwood When tested in accordance with AS/NZS 4012:1999		7.4kW	6.9kW
Minimum Average Heat Output Burning Softwood (AS/NZS 4012)		4.4kW	4.5kW
TESTING:	Laboratory	REPORT NO.	
AS/NZS 2918:2001	Applied Research	15/2757	15/2757
AS/NZS 4012:2014	Applied Research	15/2753	15/2755
AS/NZS 4013:2014	Applied Research	15/2753	15/2755

Approved Fuel

Softwood that has less than 25% moisture (measured on a dry weight basis) has not been treated with preservatives or impregnated with chemicals or glue. Must not be chipboard, particle board or laminated board, and is not painted, stained or oiled. Performance may vary from test values, depending on actual operating conditions.

Serial No.:	
Date Installed:	

Manufactured and Distributed by:

Warmington Industries 1994 Ltd
PO Box 58652, Botany 2163, Auckland
www.warmington.co.nz

NOTE A rural fire that can burn for longer periods can be ordered, but contact your local council for installation and clean air compliance requirements.

Due to continued product improvement, Warmington Ind LTD reserves the right to change product specifications without prior notification.

FIREBOX DETAILS

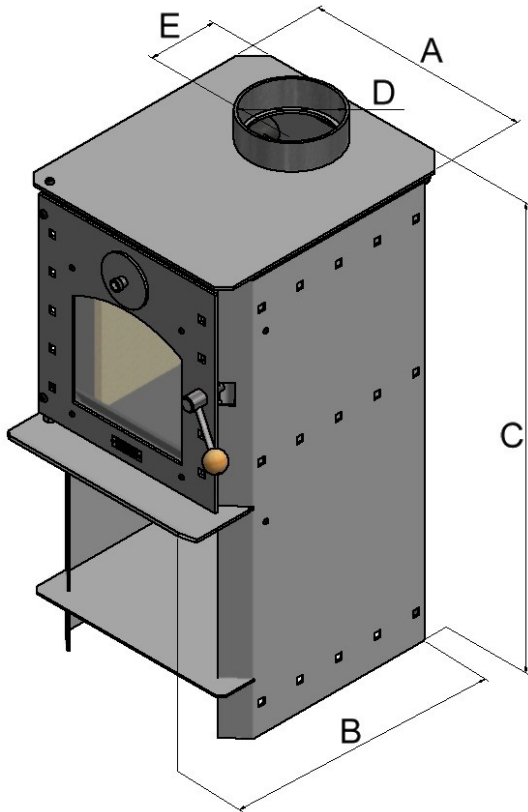

Description		
Cabinet Width	A	400
Cabinet Depth	B	520
Cabinet Height	C	820
Flue Diameter	D	150
To Flue Centre	E	123
Ceiling Height	F	2400
Minimum from fire to Ceiling	G	1500
Height from Floor Protector	H	4430±100
Emissions level dry (g/kg)		0.66g/kg
Emissions level wet (g/kg)		0.55g/kg

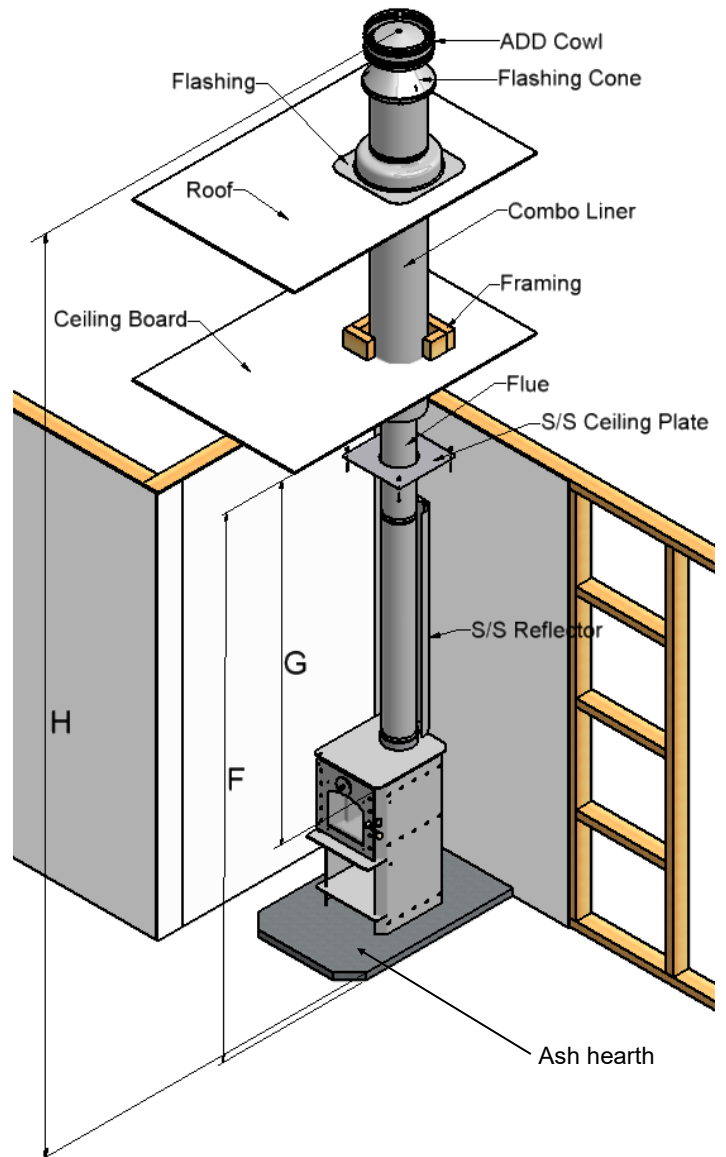

FLOOR PROTECTOR

Note: Floor Protection
Floor Protectors are normally designed to suit each individual setting
The Studio Stove requires an "ash hearth" floor protector
The Floor Protector is to comply with AS/NZS 2918:2001

Check List	
Baffle	<input type="checkbox"/>
Holding Down Brackets	<input type="checkbox"/>
Check Door Seal	<input type="checkbox"/>
Check Damper	<input type="checkbox"/>
Bricks (If Required)	<input type="checkbox"/>
Serial Number Check	<input type="checkbox"/>
Loading Badge	<input type="checkbox"/>
Packed By	<input type="checkbox"/>

Minimum Flue Height	
Flue Height	3600
Measured From Top of Cabinet	C + 3600

Due to continued product improvement, Warmington Ind LTD reserves the right to change product specifications without prior notification.

PLAN VIEW OF CLEARANCES TO COMBUSTIBLES - STRAIGHT & CORNER

Description (minimum dimensions)		1.	2.
To wall behind	I	215	100
To wall side	J	350	100
To flue centre (back)	K	338	223
To flue centre (side)	L	550	300
Hearth depth	M	952	837
Hearth width	N	660	660
Hearth projection	O*	300	300
Hearth projection from centre of flue	P	614	614
To flue centre - corner	Q	378	303
To flue centre - corner	R	535	429
Hearth depth - corner	S	1149	1043
To wall side - corner	T	175	100

* O dimension are measured from the feet.

Situation	
1.	Combustible surface with stainless steel reflective flue shield. Construction of flue shield must be in accordance with AS/NZS 2918 (minimum flue shield height is 1200mm).
2.	Non-combustible walls (including non-combustible surfaces, framing and wall linings) without flue shield, e.g. concrete/block/brick/AAC block. Hearth only needed if installed on heat sensitive floor material. Re: Clearance to a non-combustible materials, walls or surfaces. Refer to ASNZS:2918:2001 3.2.1. The clearance to a non-combustible wall (including non-combustible surfaces and finishings), can't be less than 100mm. If wet-back is fitted, refer to Situation 1. above.

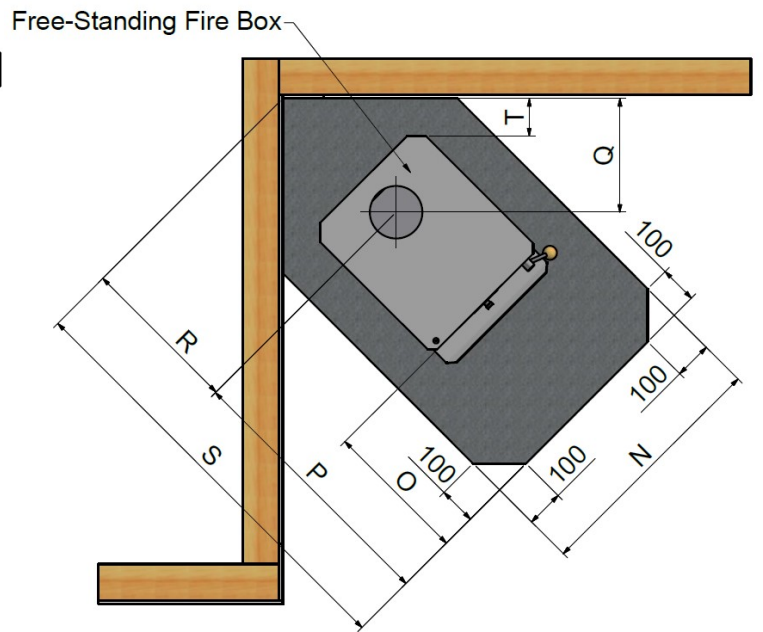
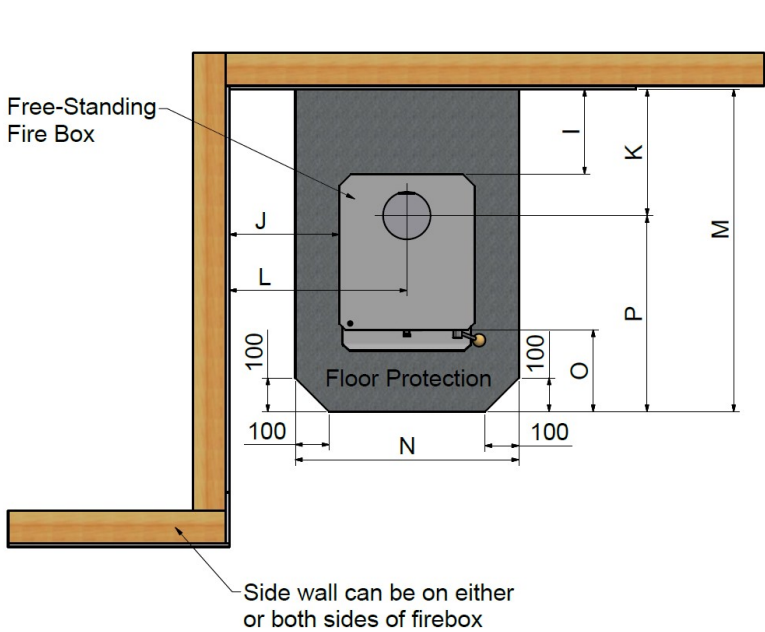

BAFFLE POSITION AND WARMINGTON AIRBACK



Note:
The Warmington Studio is fitted with an "Airback". The "Airback" is designed to be left in the firebox and act as a heat exchanger. It makes the fireplace burn more efficient and cleaner. Please note that it can not be used with water.

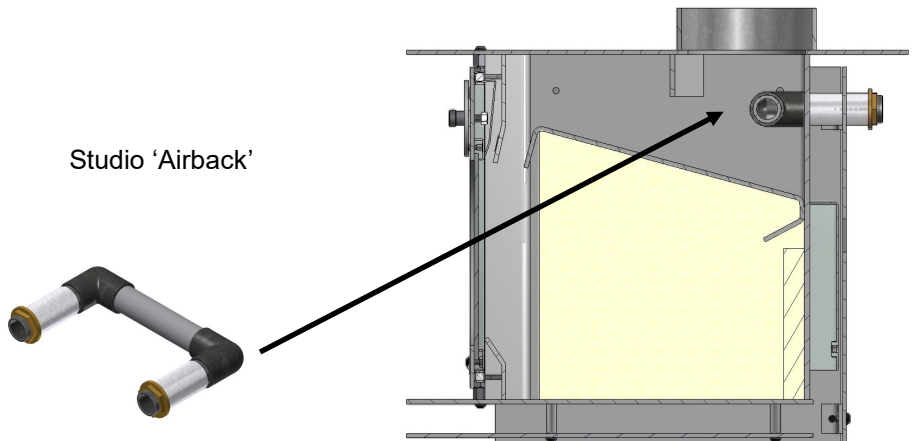

Due to continued product improvement, Warmington Ind LTD reserves the right to change product specifications without prior notification.

FITMENT OF VERMICULITE BACK AND SIDES PANELS & BAFFLE ASSEMBLY

STEP: 1

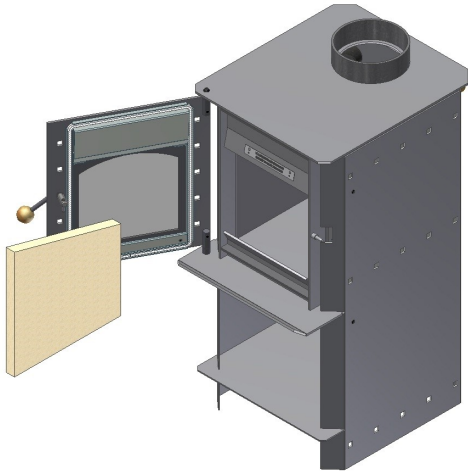

Place one vermiculite board side brick into the Firebox as shown above.

STEP: 2

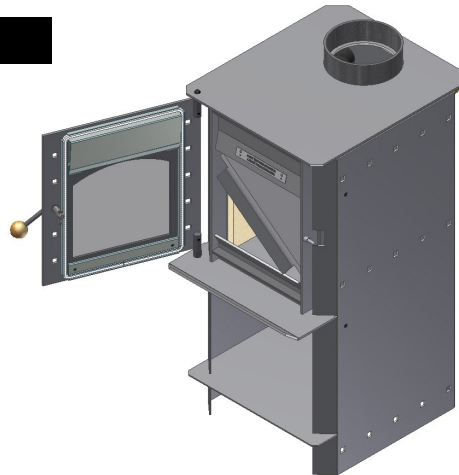

Put the steel baffle in on an angle through the door frame. Lift it up holding it horizontally resting on the one side bricks.

STEP: 3

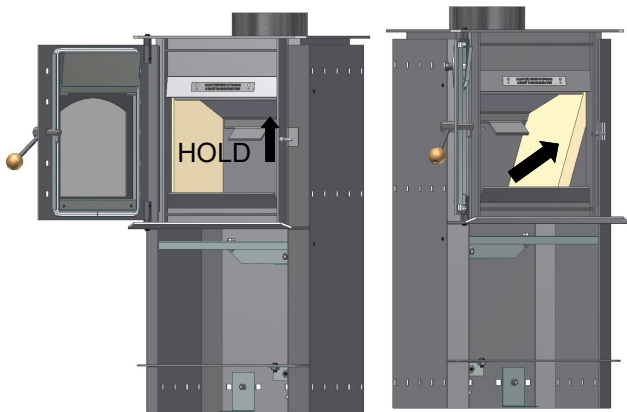

While holding up the steel baffle horizontally, insert the opposite side brick in from underneath it, as shown above. The 2 side bricks will now support the steel baffle.

STEP: 4

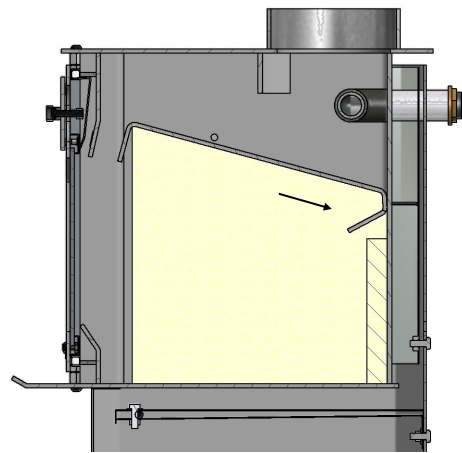

Push the baffle right to the back of firebox.

STEP : 5

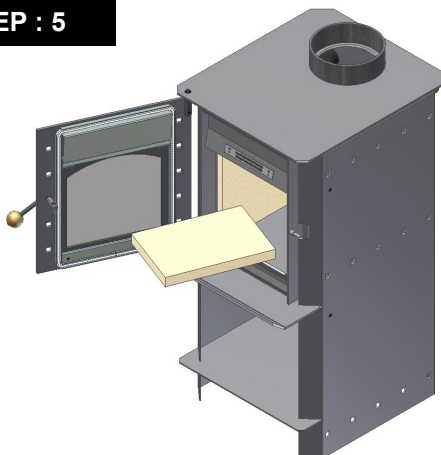

Fit back vermiculite board panel into the firebox back, ensuring that it is sitting hard against the back of the firebox.

STEP : 6

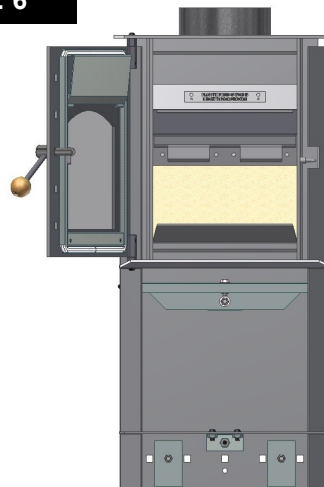

Once the vermiculite board back is in place, ensure jet inlet holes on the back plate are clear of any obstructions.

Due to continued product improvement, Warmington Ind LTD reserves the right to change product specifications without prior notification.

WETBACK POSITION

Studio 'Airback'

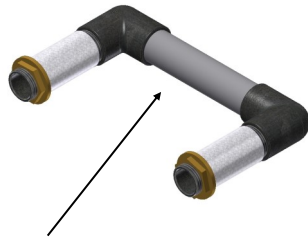

Studio Wetback

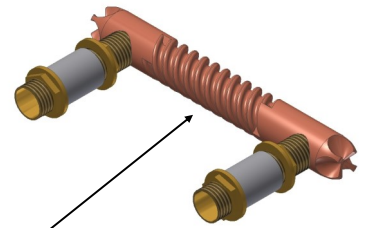

Important note:
Remove "Airback" before fitting Studio wetback.

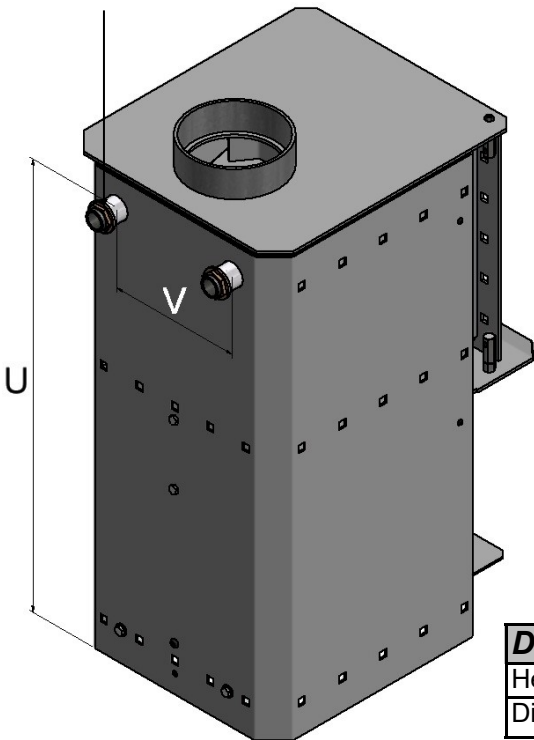

Power Out	kW
Wetback	0.7

Description		
Height from Bottom of Unit	U	750
Distance Between Outlets	V	220

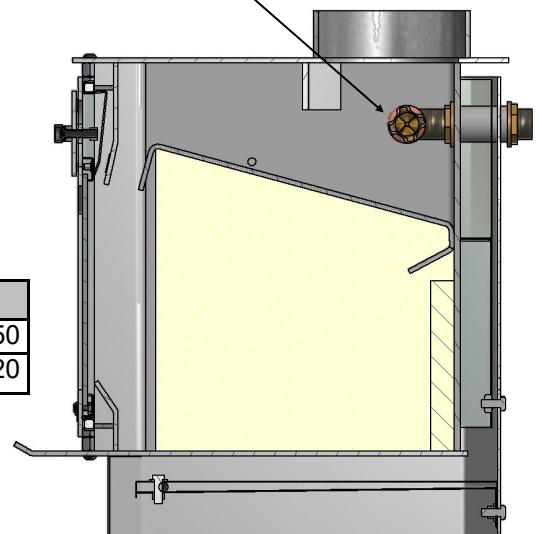

SEISMIC RESTRAINT FIXING

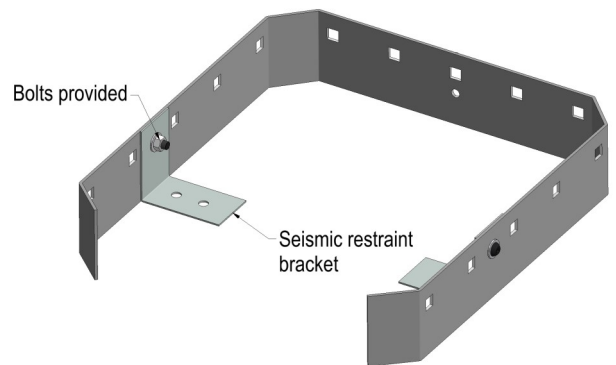
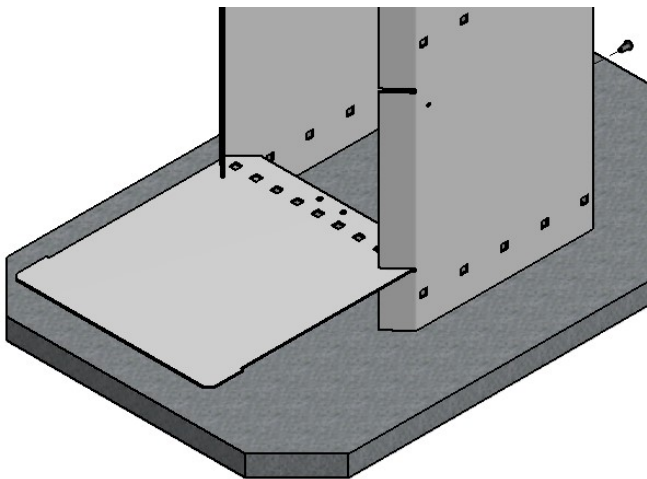

Seismic Restraint Fixing Instructions
Remove bottom tray, remove bolt at back of tray & slide shelf out
Fit seismic restraint brackets (1 on each side of unit)
Fix bracket into floor through the hearth
Replace bottom shelf and bolt back on
Note:
Consult your plumber for wet back system configurations and operation.
Wetback is to be fitted to an internal heat-sync (e.g. hot water cylinder/radiator/under floor heating etc.)

Seismic Restraint Fixing Instructions
Fix 2x seismic restraints through the hearth into the floor. They are to penetrate into the fixing by at least 3 times their diameter.
Use at least 2x 6 to 8mm dia. Dyna bolts or similar to fix fire to hearth and or through the hearth to the floor.
Fix hearth to floor with appropriate adhesive, bolt or screw.
Ensure that the seismic restraints complies with AS/ NZS 2918:2001 - refer to 3.8.

Due to continued product improvement, Warmington Ind LTD reserves the right to change product specifications without prior notification.

FLUE SYSTEM INSTALLATION GUIDE

Minimum Flue Height	
Flue Height	3600
Measured From Top of Fire	C + 3600

Flue details	No:	Studio Stove
Cowl	1	150
Cone	1	150
Top Spider	1	150
Liner Diameter Slip	1	250
Flue Diameter S/S	1	150
Flue Diameter Hi Therm Black	2	150
Combo 250/200 X 1200MM Galv	1	250
Ceiling Plate	1	150
Ceramics	4	
Double Flue Shield with Brackets	1	to suit 150

FLUE SYSTEM INSTALLATION INSTRUCTIONS

This flue kit has been manufactured in accordance with AS/NZS 2918:2001 and tested to Appendix F. To ensure safety, this flue kit must be installed as outlined in these instructions. Heater and flue pipe clearances from combustible walls must be in accordance with heater manufacturer's specifications and AS/NZS 2918:2001. These installation instructions are for tested appliances only.

Please note: EACH INSTALLATION WILL VARY DUE TO UNIQUE INSTALLATION REQUIREMENTS.

- STAGE 1:** Locate heater in its proposed position and mark a point on the ceiling that is directly above the centre of the heater's flue outlet. Check that the heater's location allows the **Outer Casing** to clear all structural roof timbers.
 - STAGE 2:** Cut a 250mm **Square** hole in ceiling. Directly above, cut a hole in roof to accommodate **Outer Casing**.
 - STAGE 3:** Fit timber nogs around ceiling and roof holes, i.e. nogs form a 250mm square aperture, which allows air to circulate freely over the **Outer Casing** surface.
 - STAGE 4:** Position the **Outer Casing** so that it is flush with the underneath of the ceiling and protrudes through the roof the required height (Refer to AS/NZ 2918:2001 if more details are required). When calculating roof penetration height, allow for an extra 500mm that can be achieved by using the **Outer Casing Slip Extension**.
 - A:** If the flue is within three metres of the ridge, the **Outer Casing** must protrude at least 600mm above the ridge of the roof.
B: If the distance from the ridge is more than three metres, the **Outer Casing** must protrude at least 1000mm above roof penetration.
 - STAGE 5:** Fix an appropriate flashing around the **Outer Casing** to seal onto the roofing material.
 - STAGE 6:** Assemble **Flue Pipes** together ensuring seams are in line. Secure each joint with three rivets or self-tapping screws. **Flue Pipes** must be assembled with crimped ends down (towards heater).
 - STAGE 7:** Place **Ceiling Plate** over heater flue spigot, ensuring the folded edge up stands are facing ceiling.
 - STAGE 8:** From the roof, lower **Flue Pipes** through **Outer Casing** into position. Ensure not to scratch the hi-therm Flue coating. The hi-therm Coating can be touched up with an approved Spray can (Stovebright). **NOTE: Some fires require the crimped end of the flue that fits into the Fires flue spigot to be trimmed back to a snug fit. Seal flue to Fire box spigot.**
 - STAGE 9:** From the roof, slide the **Inner Casing** into the **Outer Casing**, around the flue, until it rests 12mm above ceiling level on the **Swage Ring of the Outer Casing**.
 - STAGE 10:** Before securing the **Outer Casing Slip Extension** to the **Outer Casing** with three rivets or self tapping screws, ensure the **Flue Pipes** extends above the top of the **Outer Casing Slip Extension** 145mm APPROX. The fitment of the **Cowl**, **Flashing Cone** and **Flue** is required to form a seal by the flange on the **Cowl**. Adjust **Slip Extension** to obtain this measurement. If minimum roof penetration heights described earlier can not be achieved, add sufficient stainless steel **Flue Pipe**.
 - STAGE 11:** Fit **Top Spacer Bracket** to the **Flue Pipe** making sure the lugs fit snugly inside **Outer Casing Slip Extension**. Make sure **Top Spacer Brackets** fits hard down onto **Outer Casing Slip Extension**.
 - STAGE 12:** Fit **Flashing Cone** over the **Flue Pipe** and push down firmly onto **Top Spacer Bracket**. Optional to secure with a rivet or self-tapping screw. The **Flashing Cone** should be flush with or 5mm above the finished **Flue Pipe**.
 - STAGE 13:** Fit **ADD Cowl** but do not secure permanently, as removal for flue cleaning will be necessary. The **Cowl** will fit tight down onto the **Flashing Cone** forming a seal—ensure that the seal is formed. (The **Cowl**, **Flashing Cone** and **Flue** can be secured with a Stainless Steel screw but provision must be made for the removal of the **Cowl** for cleaning of the flue system.
 - STAGE 14:** Fasten **Ceiling Plate** to ceiling using screws and spacers provided. Ensure an even air gap around **Flue Pipe** when fixing. Remove protective plastic from **Ceiling Plate**. **N.B.** 12mm air gap between ceiling plate and ceiling must be maintained.
 - STAGE 15:** Fit of the Flue Shield, fit **Bracket** to **Flue Pipe** above firebox and the bracket into the flue spigot on the fire.. Attach **S/S Reflector** to **brackets**, ensure that the plastic coating is removed from all the surfaces before lighting the fire.
- NOTE:** It is the responsibility of the installer to ensure that the installation of the flue kit complies with AS/NZ 2918:2001, the appliance manufacturer's specifications for flues and that relevant Local Body requirements are adhered to.

Note: FLUE SYSTEMS casing.
 Flue system may require to be doubled lined to comply.
 Ref. AS/NZS:2918:2001 4.3 Flue pipe casing

NOTE:
 Ensure that a Standard Tested Warmington Flue system is used on the Warmington fires.

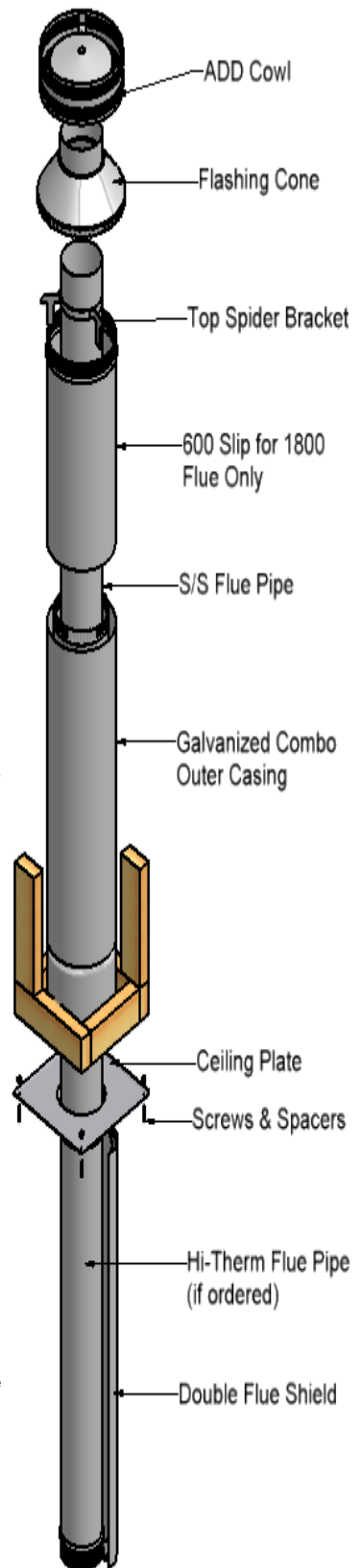

Due to continued product improvement, Warmington Ind LTD reserves the right to change product specifications without prior notification.

FLUE HEIGHT MINIMUM DETAILS

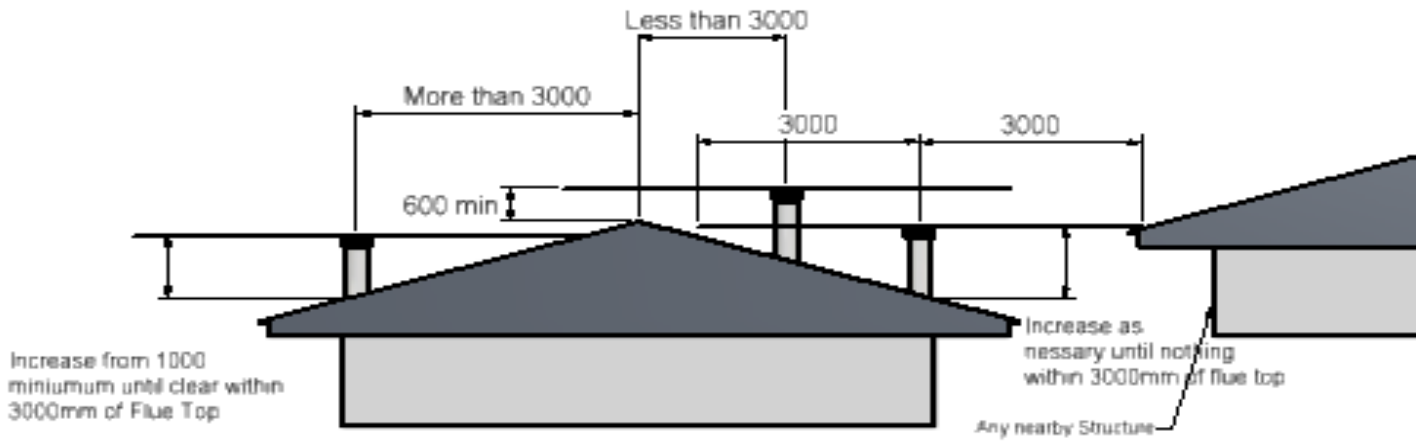

The flue exit is to comply to AS/NZS 2918: 2001

3D View

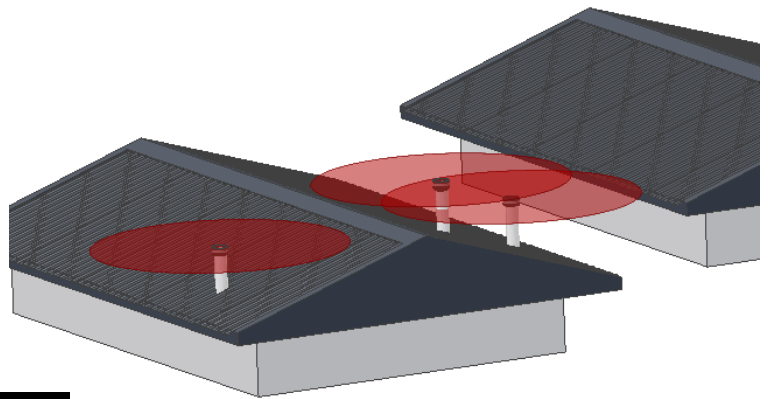

FLASHING—TO COMPLY TO THE BUILDING CODE (E2)

Note: ROOF FLASHINGS GENERAL
 Flashing are to be complaint to the building code and the design will vary depending on the type of roof.
 Each installation is unique and your Installer will advise of the most appropriate flashing method to comply.

FRAME OUT - TRIM OUT DETAILS FOR FLUE SYSTEM

Note: FLUE SYSTEMS casing
 Flue system may require to be Doubled lined to comply. Ref AS/NZS:2918:2001 4.3 Flue pipe casing

Note:
 External Requirements
 Refer to AS/NZS2918:2001 4.9.1

- Install flue system to AS/NZS2918:2001
- When using a rubber or bitumen flashing (butynol, dectite) an additional flue pipe baffle is required.
- All external air vents & ceiling penetrations must be bird proofed with permanently fixed screens.
- All flashing to comply with E2.

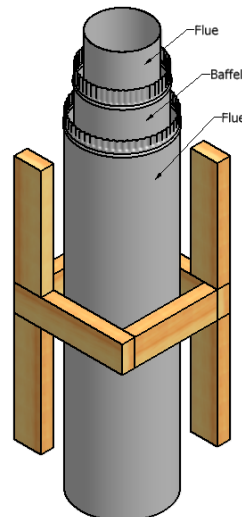

Y = Liner Diameter

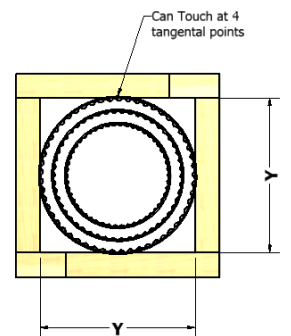

Due to continued product improvement, Warmington Ind LTD reserves the right to change product specifications without prior notification.

Studio Door Glass Fitment

No. 1

The Studio door glass is a special heat resistance glass designed for use in fires.

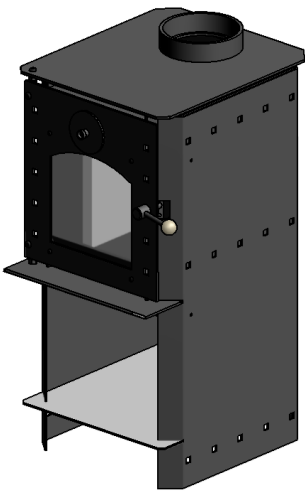

No. 2

The glass can be replaced with the door still fitted to the fire. Loosen the 4 cap-screws on the front of the door that retain the glass and remove the bottom glass retainer.

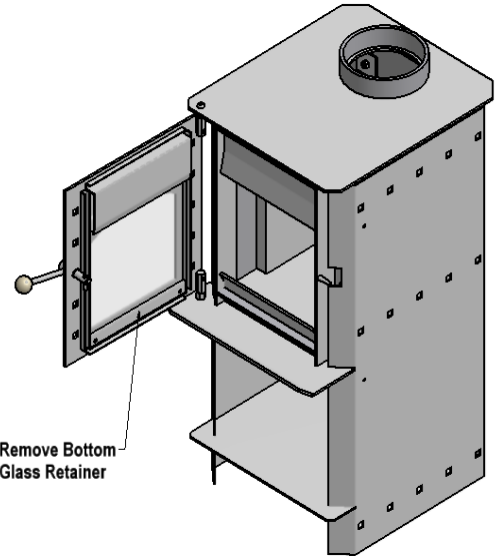
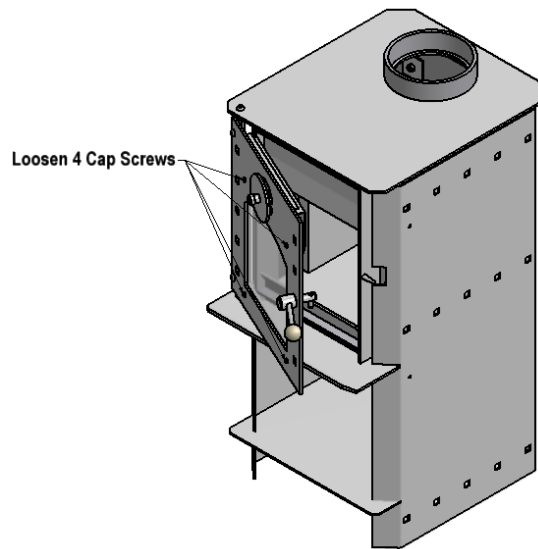

Parts	
Warmington Studio Door Glass	1 x

Tools	
3mm Allen Key	1 x

No. 3

Slide the glass down towards the bottom glass retainer and remove the glass and any shards.

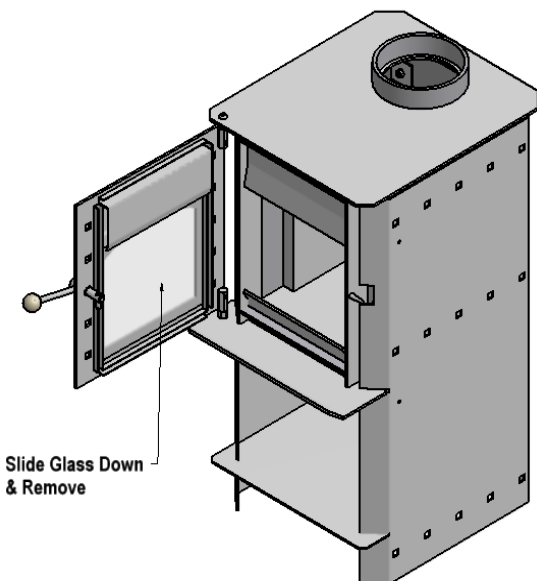

No. 4

Ensure that both glass & door surfaces are clean and true.

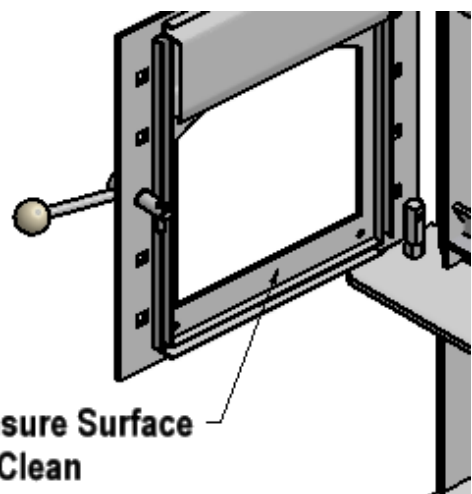

Due to continued product improvement, Warmington Ind LTD reserves the right to change product specifications without prior notification.

No. 5

Place the new glass into the door at the bottom.

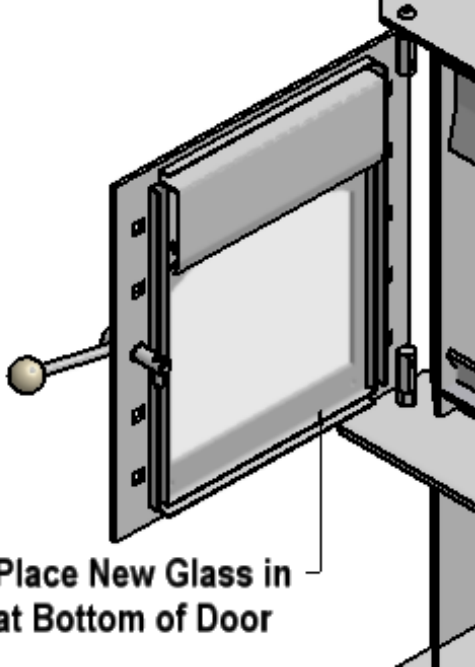

Place New Glass in at Bottom of Door

No. 7

Slide the glass up and into position, ensure that the bottom glass retainer holes are clear to take the cap screws. Fit the bottom glass retainer.

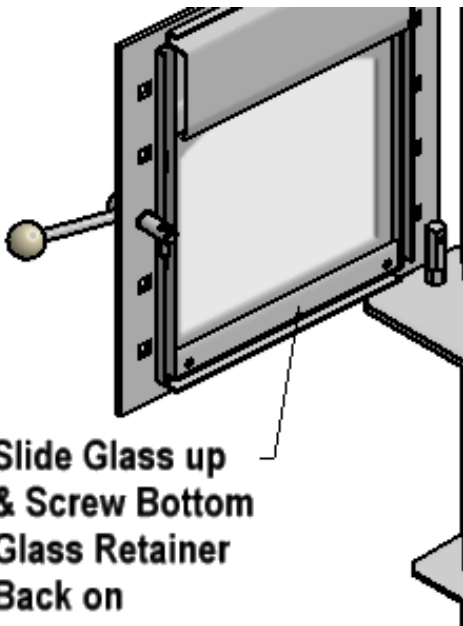

Slide Glass up & Screw Bottom Glass Retainer Back on

No. 6

With a 3mm allen key, hook under the air dam and lever the top door retainer up, at the same time slide the glass up and under the top door retainer. Repeat for the other side.

NOTE:

Take care not to break the glass.

1st : Lever Air Dam & Retainers with suitable Tool

Air Dam
Door Retainers

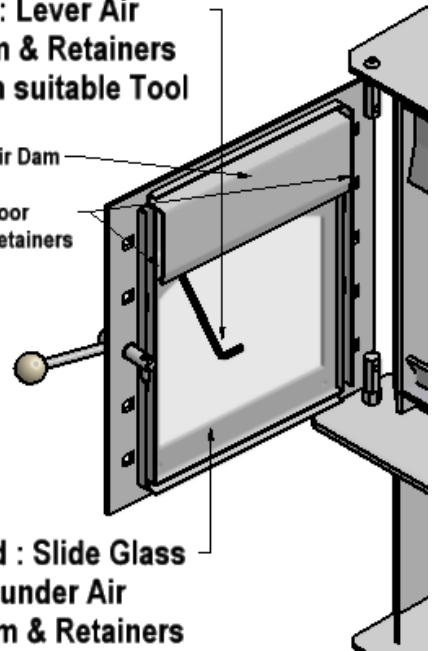

2nd : Slide Glass up under Air Dam & Retainers

No. 8

IMPORTANT NOTE :

Nip up the cap screws for the top and bottom glass retainers.

DO NOT OVER TIGHTEN AS GLASS MAY CRACK/BREAK.

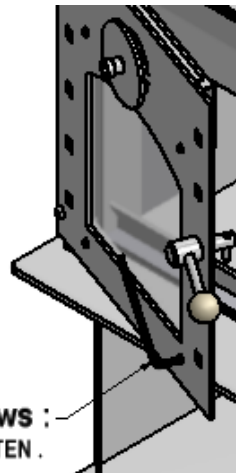

Tighten 4 Screws : DO NOT OVER TIGHTEN .

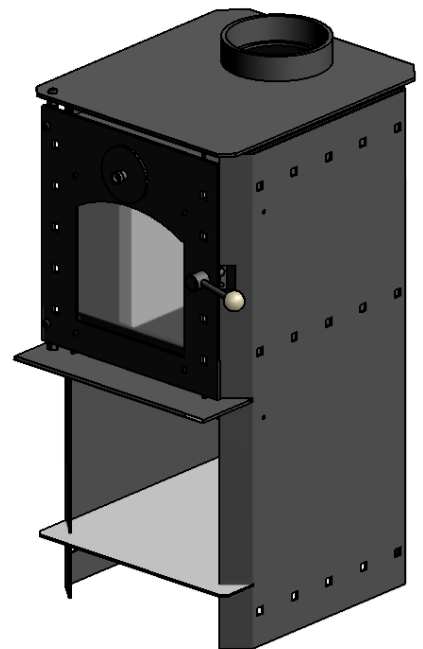

Studio Door Adjustment Instructions

No. 1

The Studio door and hinge has been designed to give a wide range of adjustment.

No. 2

Have all the screws and the nuts just loose so the door can move with a slight force.

No. 3

Close the door and nip the handle closed. Ensure that the handle is only just nipped.

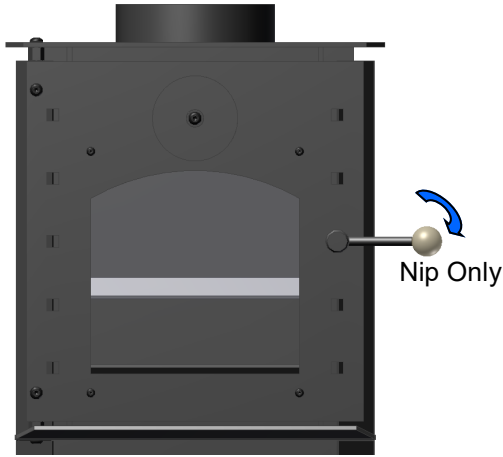
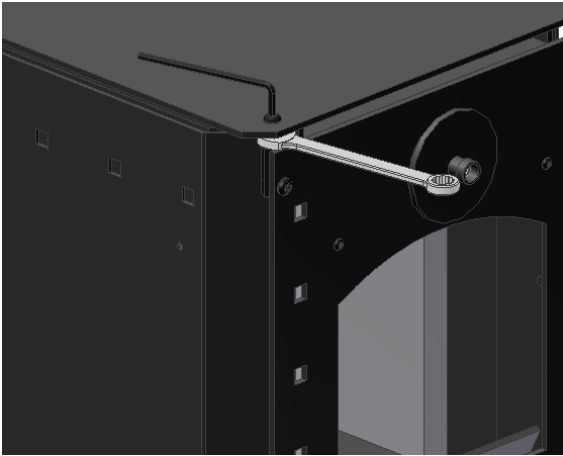
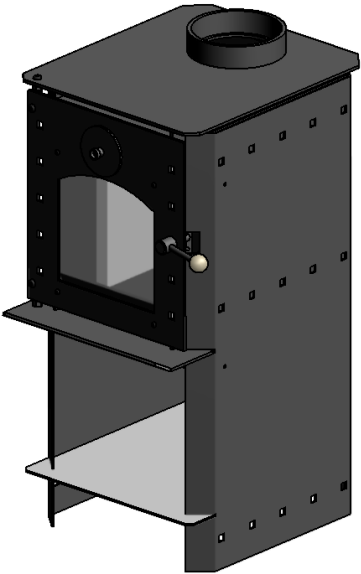

No. 4

Line up the door across the top of the fire and ensure that it is parallel.

No. 5

Tighten up the cap screws on the top & bottom door front first.

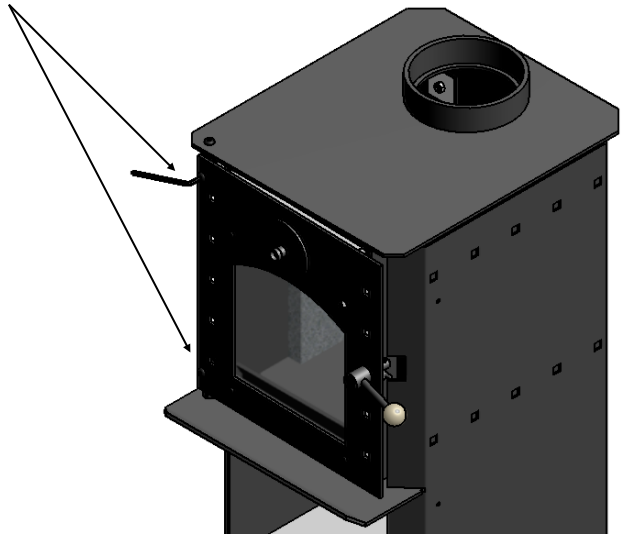
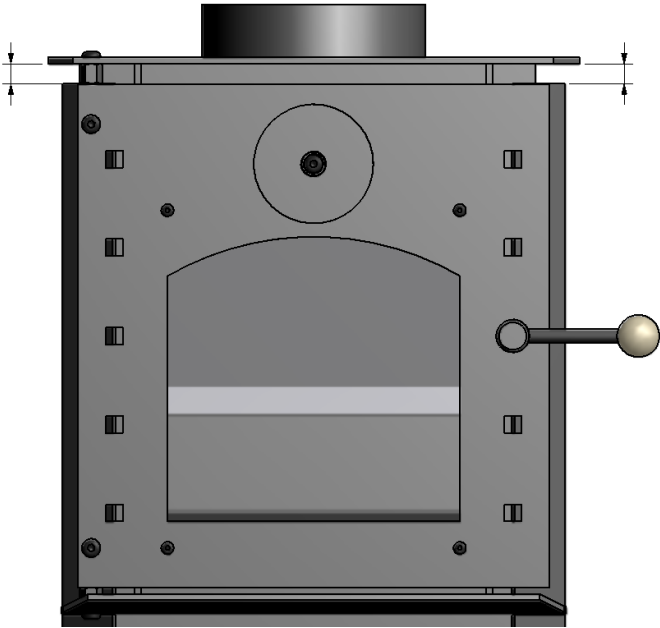

Due to continued product improvement, Warmington Ind LTD reserves the right to change product specifications without prior notification.

No. 6

Ensure that the door is hard back on the hinge side and tighten the top and bottom nuts while holding the button head cap screw with the 5mm allen key and spanner.

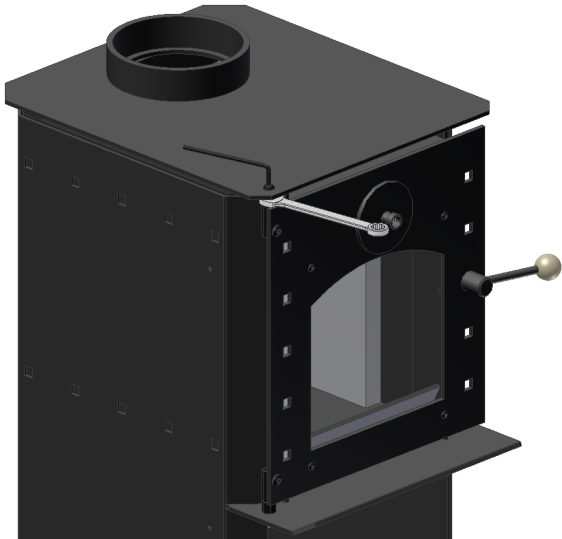

No. 7

Ensure that the door is parallel to the top of the fire.

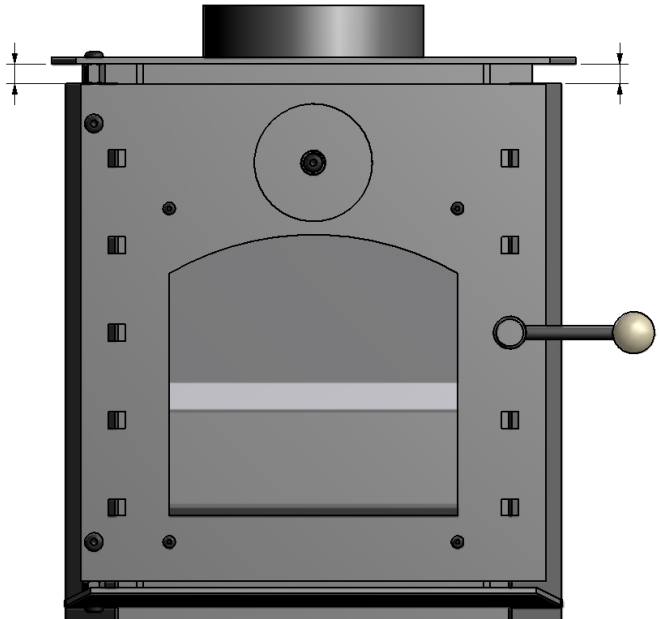

Check both ends of the doors to make sure it is parallel to the unit.

No. 8

Ensure that the door seal is mating with the door frame and making a seal by looking along the door and seal as they mate. If it is not mating correctly, repeat adjustment process.

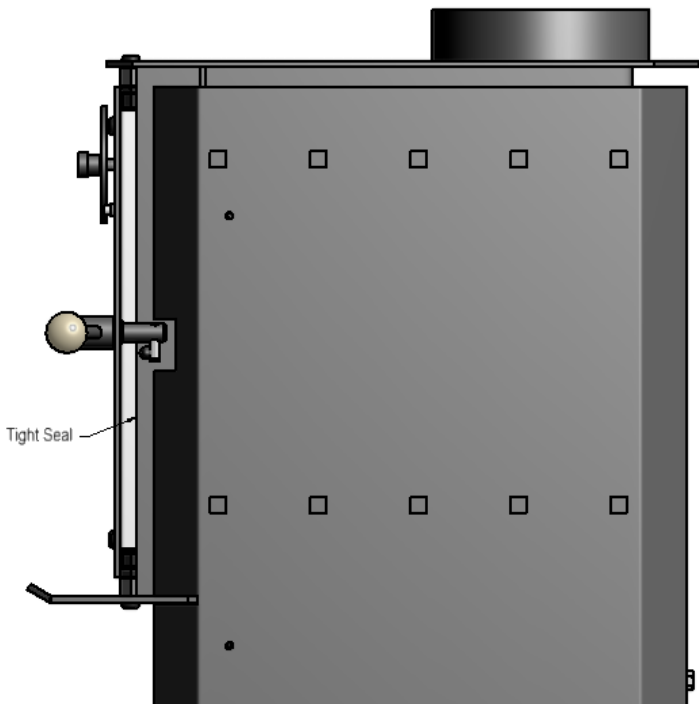

No. 9

Check the seal by opening the door and placing a piece of newspaper between the door frame and the door seal, close the door and see if there is some resistance when removing the newspaper. This will prove if the door is sealed. If seal is not made, repeated the adjustment process or a new door seal rope may be required or repeat the adjustment process.

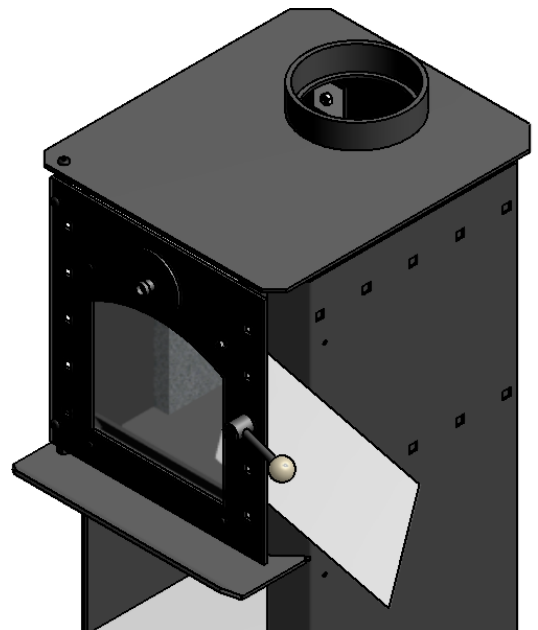

Nip up screws while holding door in place, then tighten fully with a 5mm allen Key.

GENERAL INFORMATION & OPERATION

1. Double Skin

The Studio Stove convection stove – it has an inner and outer skin whereby room air flows between the surfaces, thus becoming hot and efficiently heating the room. Because the outer skin stays relatively cooler, this type of stove is much safer than a full radiation stove (i.e. pot belly) the top & side surfaces will get hot.

2. Burns Twice

This statement is applied to many modern stoves. The combustion chamber is very efficient – air and volatile gases mix together and are more fully burnt. Spent gases exit through the flue.

3. Burn control and operation

The air intake disc on the door controls the amount of air drawn into the stove & thus the combustion rate.

- When lighting the stove, the air control should be fully open (turn the air control anti-clockwise).
- Place paper or fire lighters into the base of the firebox.
- Arrange kindling on top of paper or firelighters, allowing air to move easily through the kindling.
- Light the fire around the base to ensure good ignition of paper or firelighters.
- Leave the door ajar 5 to 10 mm to aid with speedy ignition of the fire. **Do not run the fire for long periods with the door ajar as damage may result.**
- When the fire is happily burning the main fuel loads can be placed into the fire, from the front to the rear in a lined pattern, ensuring that the flames can easily move through the fuel load (**max tested fuel load approx. 2.2kg**).
- Close the door to ensure a seal to the firebox. Once the fire is fully established and burning brightly the air supply can be considerably reduced to control heat output (and fuel consumption). Note, the air control is designed such that even when fully closed some air still enter the firebox. This keeps unwanted flue emissions to a minimum.

4. Removing ash

After using your fire for a few weeks, you will find ashes accumulate in the firebox. The ash can be removed easily through the fire door when the fire is completely out. The amount of charcoal in the ash is often a good indicator of how well you are operating the fire. If there is no charcoal and only very fine ash then you are doing an excellent job. If there is a lot of charcoal you may be turning the combustion air down too soon after refueling, or not raking the charcoal to the combustion air inlet, or turning the combustion air down too low to support efficient combustion, or all of the above. Warmington wood-burning fires work best when a small amount of ash is left (approximately 25mm deep) in the firebox after cleaning as this aids with stable burning. The ash should be placed in a non-combustible container with a tightly fitting lid and moved outdoors immediately to a location clear of combustible materials.

5. Cooking

Because the top of the fire is in direct contact with the flame, it offers a large cooking surface. Ideal for entertaining at home/holiday homes or farm cottages. If spillage occurs, clean the surface with a soft cloth and dish washing liquid and avoid scratching the surface.

6. Storing/drying fuel

The space below the firebox can be used as a wood storage and drying area. Damp wood is dried naturally while it is stored. Use dry timber preferably cut and stored under cover from the previous year.

PURCHASING THE FIREWOOD

The quality of the firewood you burn can have a dramatic effect on the efficiency and operation of the heater. The main factors that affect the burning characteristics of firewood are moisture content, tree species and piece size.

The moisture content of the wood affects the rate at which burns and the efficiency of combustion. When trees are cut, wood moisture content ranges between 35 and 60 percent by weight. If you attempt to burn wood this wet, it will be hard to ignite, slow to burn and will hiss and sizzle in the firebox. A lot of energy will be consumed in boiling off the excess water that the efficiency of combustion and the heat to your home will be low, condensation and corrosion may be occurring in the flue and smoke may be causing problems to your neighbours. Properly seasoned wood ignites readily and burns efficiently.

Firewood should be cut and split in the early spring and stacked under cover, with good ventilation, to be ready for burning when required. Look and check for cracks in the end grain as a sign of dry wood. The stacks of firewood should be in an open area so that air can circulate between them. During the summer, as warm breezes flow through the stacks, carrying away the evaporating water, the moisture content of the wood will fall to around 20 percent. At this moisture content the wood is ready for burning.

Although the energy content of dry wood per kilogram is almost the same regardless of species, softwoods and hardwoods burn differently because of differences in density. Softwoods, such as pine, are less dense than hardwoods like gums, Manuka or ironbark. A denser wood will produce a longer-lasting coal bed, while a less dense wood will bring a fire to an optimum burning temperature more quickly.

The size of the firewood pieces affects the rate of combustion. Larger pieces ignite and release their energy more slowly than small pieces. Smaller pieces are better for short, hot fires and larger pieces are preferable for extended firing cycles. In general, commercial firewood dealers produce firewood in larger pieces than modern wood-burning appliances can handle. It is often necessary to split some of the wood again before using it.

Firewood harvesting can have an effect on native woodlands and a variety of threatened species. Dead standing and fallen timber provides habitat for numerous species of animals and birds. Wood heater operators should be encouraged to be sensitive about the source of their firewood. If collecting it privately, operators should leave some dead wood behind as it provides habitat for birds and animals.

GENERAL INFORMATION & OPERATION cont..

6. Heat Output

A maximum heat output of approximately 13kW can be expected with dry wood. Due to the clean air requirements, there is reduced control of the minimum heat output, and the fires have limited burn periods. The height of the flue system can have an effect on the draw, control and burn periods of the fire. The stove can heat an area of approximately 100—140 square meters.

NOTE : The condition, moisture content and type of wood burned will have a direct result on the performance of the fire.

A rural fire that can burn for longer periods can be ordered, but contact your local council for installation and clean air compliance requirements.

7. Construction

The firebox & door is constructed from 5mm steel plate. The outer skin and tray are constructed from 3mm steel plate.

8. Finish

High temperature steel parts are finished with a matt black high temperature paint designed to withstand the rigors of normal combustion.

9. Glass Door

When in operation, the full view of the combustion process can be seen through the large ceramic-glass window. This window is kept clean by the inlet air passing from top to bottom over the glass. Any build up of residue that may occur on the glass can be removed with a mild abrasive liquid cleaner or proprietary stove glass cleaner. Wet wood is more likely than dry wood to produce window-marking emissions.

10. Testing

The Studio Stove firebox has been tested and approved to AS/NZS 2918:2001 regulations for solid fuel burning heaters & also to AS/NZS 4012:2014 for compliance with MfE (Ministry for the Environment New Zealand) clean air requirements in New Zealand & Australia. The stove has not been designed to operate with the door open for long periods. Clean air testing is conducted with the door closed. See the attached data sheet on page 2 & the data plate attached to the fire. Contact with your local TA (Territorial Authority) to check for local compliance.

11. Flue System

The installation and construction of the flue system must comply with AS/NZS 2918:2001. The fire requires a Warmington tested and approved flue system only, as tested to AS/NZS 2918:2001. The tested flue system should not be modified in any way without the written approval of the manufacturer. Any additional flue components to the flue system must comply with AS/NZS 2918:2001.

12. Floor Protection

Floor protectors are normally designed to suit each individual setting. The installation and construction of the floor protector must comply with AS/NZS 2918:2001. The Studio Stove requires an ash hearth (floor protector) as needed for some types of wood burners.

13. Maintenance

The operation, components and general condition of the fire and flue system need to be checked annually, or more frequently if required. Repair or replace parts when necessary. For more information, contact your local Retailer.

The chimney, firebox are to be cleaned and swept annually or more frequently if required.

Chimney Maintenance:

To clean the chimney, remove baffle plate inside the top of the firebox & close the door. With a ladder, access the roof and remove the cowl assembly. Make sure the door is closed on the fire & close air control (turn clockwise) to ensure soot etc. can fall into the firebox. With a chimney sweeping brush that suits the flue diameter, clean the flue ONLY from the top down. Remove soot/ash from the firebox. This is recommended to be done annually before each winter.

Firebox:

Keep your stove clean by polishing all over with a soft cloth when unit is cool. In humid climates, more interior firebox corrosion will occur in the summer months than in winter. The stove's life can be greatly extended by cleaning the firebox interior at the end of winter and spraying with Stovebright high temperature black paint.

14. Wetback

On special order a wetback model can be supplied. This unit acts as a hot water booster, producing about 1kW. The wetback sits in the firebox. The inlet and outlet are at the fire back and require standard 25mm pipe connections to the threaded brass pipe of the wetback. Inlet and outlet pipes are at the same height permitting flow of water in either direction, but need to be correctly connected by the plumber. **Note: Not all fires have the provision for a wetback.**

GENERAL INFORMATION & OPERATION cont..

15. Suggested procedures for soot or creosote fire”

In the event of a soot or creosote fire

- Alert all the people in the house. Either have them leave, or be ready to leave.
- Call the fire department.
- Suppress the fire the best you can until the fire department arrives, being careful of your own safety. Be sure you always have a way out of the house should the fire get out of hand.

If you can, being careful of your own safety:

- Close the air inlet(s) of the appliance.
- Discharge a dry chemical household fire extinguisher into the appliance.
Use a chimney fire extinguishing product (water on the base of the fire will turn to steam and aid to put out the fire)

16. Warranty - for full details and conditions on product Warranties, contact your Authorised Retailer.

The Studio Stove is guaranteed against faulty workmanship and materials for a five-year period.

The black surface while extremely durable and long lasting, may need buffing lightly with a soft cloth from time to time to retain its colour and appearance, or touching up with an approved high temperature paint i.e. Stovebright.

Not included in Warranty: (list of Warmington genuine replacement parts)

1. Glass in the doors (Robax glass 5mm fire box)
2. Door seals. Firebox
3. Internal baffle system (consumable)
4. Firebox linings - (consumable - may not be fitted with some models)
5. Flue system
6. Paint (Stovebright)
7. Handles.

17. Installation

The fire is to be installed by a approved Warmington installer or an approved NZHHA SFAIT installation technician. See www.nzhha.co.nz/members for a NZHHA SFAIT installer in your area.

GENERAL INFORMATION ON PAINT & FINISHING

Information on the paint coating is on the web site: http://www.forrestpaint.com/stovebright/troubleshooting_guide1.html

When lighting the fire for the first time:

Ventilate the house during the first three times the stove is used. The paint on the stove will give off smoke heavy with carbon dioxide and has an odour. Without adequate ventilation, concentrations of smoke could irritate, or be upsetting. Babies, small children, pregnant women and pets should not be in the area due to these carbon dioxide fumes causing an imbalance in the air quality. Open doors and windows and use a fan if necessary. After these initial burns, the paint will be set and there should be no more smoke.

Don't touch the surface, it will be soft and gummy during this phase. Once set, it will not be soft again.

Most stoves stop smoking after 3 burns. The first two should be at 250 F (121 C) for 20 minutes or about half a normal fire. Do not let the stove cool down significantly between burns. The last fire should be between 500 F (260 C) and 700 F (371 C) for at least 45 minutes.

The point being, operate slowly without a hot fire. If the stove gets too hot too quickly, the paint will crack. Owners of stoves that have a door gasket should check with the stove dealer about leaving the door ajar during this process to keep the gasket from sticking to the jam.

Stoves with a cooler surface temperature and those that were previously painted with another colour will take longer to set. This process can usually be observed by the effect of the paint turning flat as the heat radiates out from hotter parts of the stove.

Summary on Setting High Temp Paint:

Read Stove Manufacturer instructions.

Babies, small children, pregnant women and pets should leave the area during the paint setting phase.

Ventilate well.

Paint surface will look “wet” and will smoke.

Do not touch paint surface during this process.

Set slowly with successive burns.

Call your Warmington retailer, or Installer if you have any further questions.

GENERAL NOTES: AS/NZS 2918:2001

NOTES:

- Warranty - for full details on product warranties, contact your local Authorised Warmington Retailer.
- For the fire operational and maintenance instructions visit www.warmington.co.nz and download the PDF.
- Correct installation, operation and maintenance must be maintained to comply with Warmington’s Warranty.
- The appliance and flue system must be installed in accordance with AS/NZS 2918:2001 and the appropriate building codes.
- The flue system and fireplace is to be swept annually, or more frequent if required.
- The appliance and flue system has been tested to AS/NZS 2918:2001.

WARNINGS:

- **WARNING: ANY MODIFICATION OF THE APPLIANCE THAT HAS NOT BEEN APPROVED IN WRITING BY THE TESTING AUTHORITY IS CONSIDERED AS BREACHING AS/NZS:4013.**
- **WARNING: DO NOT USE FLAMMABLE LIQUIDS OR AEROSOLS TO START OR REKINDLE THE FIRE.**
- **WARNING: DO NOT USE FLAMMABLE LIQUIDS OR AEROSOLS IN THE VICINITY OF THIS APPLIANCE WHEN IT IS OPERATING.**
- **WARNING: DO NOT STORE FUEL WITHIN HEATER INSTALLATION CLEARANCES.**
- **WARNING: WHEN OPERATION THIS APPLIANCE AS AN OPEN FIRE USE A SPARK SCREEN.**
- **CAUTION: THIS APPLIANCE SHOULD BE MAINTAINED AND OPERATED AT ALL TIMES IN ACCORDANCE WITH THESE INSTRUCTIONS**
- **CAUTION: THE USE OF SOME TYPES OF PRESERVATIVE-TREATED WOOD AS A FUEL CAN BE HAZARDOUS.**

Model	Estimated kW	Peak output to room kW
Studio Stove	13	8.3
Studio Stove w/Wetback	12	7.7

Tested Fuel Load (softwood)	Weight in kg	Firebox litres approx.
Studio Stove	up to 2.17	23

NOTE: For operation instructions download from the website www.warmington.co.nz



Warmington Industries 1994 LTD
PO Box 58652, Botany 2163, Auckland
www.warmington.co.nz

Due to continued product improvement, Warmington Ind LTD reserves the right to change product specifications without prior notification.