



*Please Read Instruction Manual carefully
before Assembling.*



WARNING: Heavy object

The Matakana Corten cabinet and Firebox complete unit weights 580kgs. To reduce the risk of lifting related injuries, serious harm, or damage to your Product, we recommend that a minimum of two people assemble the corten cabinet and the use of a lifting device for lifting the Firebox. It is important to use proper lifting techniques when lifting and/or moving the unit. Below are some guidelines for safe lifting.

- Check your environment for obstructions and slippery surfaces.
- Lift with your legs, not your back.
- Bend at your knees, keeping the back straight.
- Centre your body over the unit. Keep the feet about shoulder width apart.
- Lift straight up smoothly.
- Keep your torso straight; do not twist while lifting or after the load is lifted.



2X PERSON RECOMMENDED

PARTS

FASTENERS

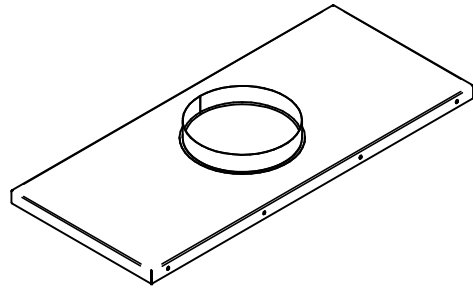

952329-Cap Assembly (x1)

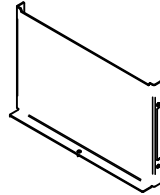

952339-woodbox Side Panel (x2)

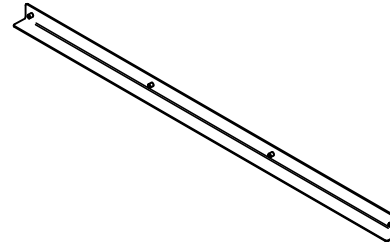

952328-Stiffener (x2)

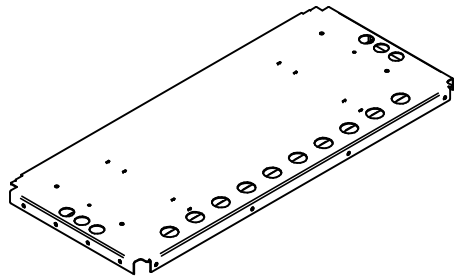

952323- Inner Top Panel Assembly (x1)

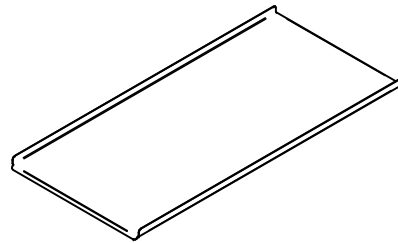

952333- woodbox Heat Shield (x1)

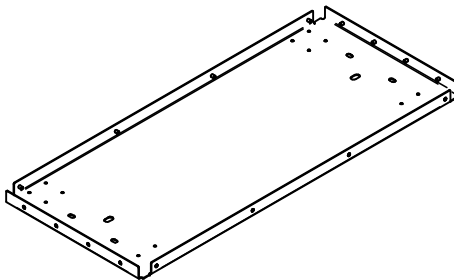

952326-Bottom Panel (x1)

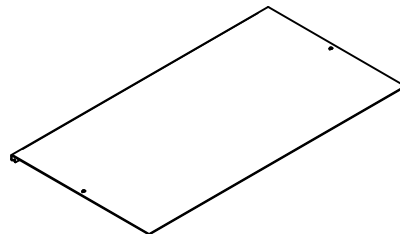

952334- woodbox Floor Panel (x1)

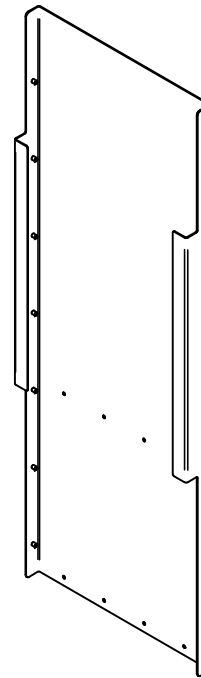

952339- Side Panel (x2)

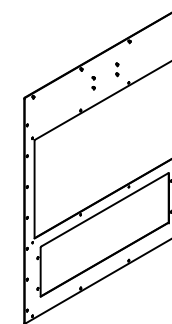

952338-Front Panel (x1)

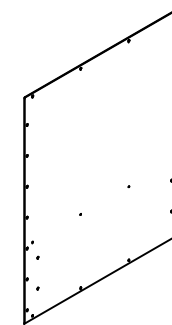



952337 Rear Panel (x1)

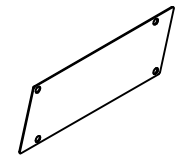

952335- Logo (x1)



952336- Logo Backing Plate (x1)

- 
- 
- 523041- Washer (x4) 522908- Binx Nut (x4)
- 
- 521065-Button Head Screw x (90)
- 1 x P-000108 - CRC Roof and Plumber's Silicone, 310mL

Tools required for assembly- not included in kit

- Allen Key
- Spanner
- Caulking gun
- Rubber Mallet

① - Fasten inner top panel assy to side panel

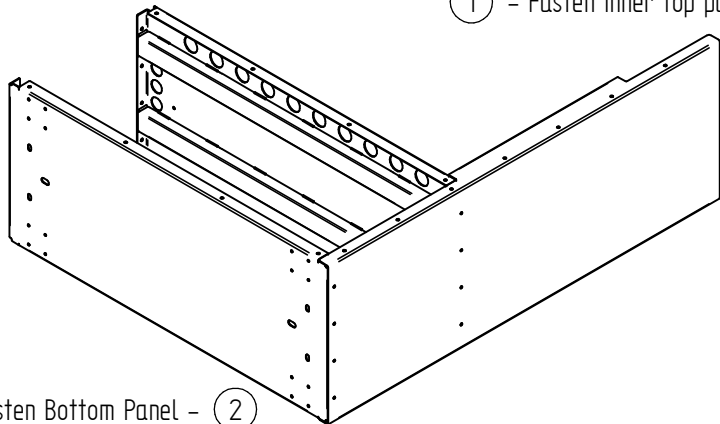

Fasten Bottom Panel - ②

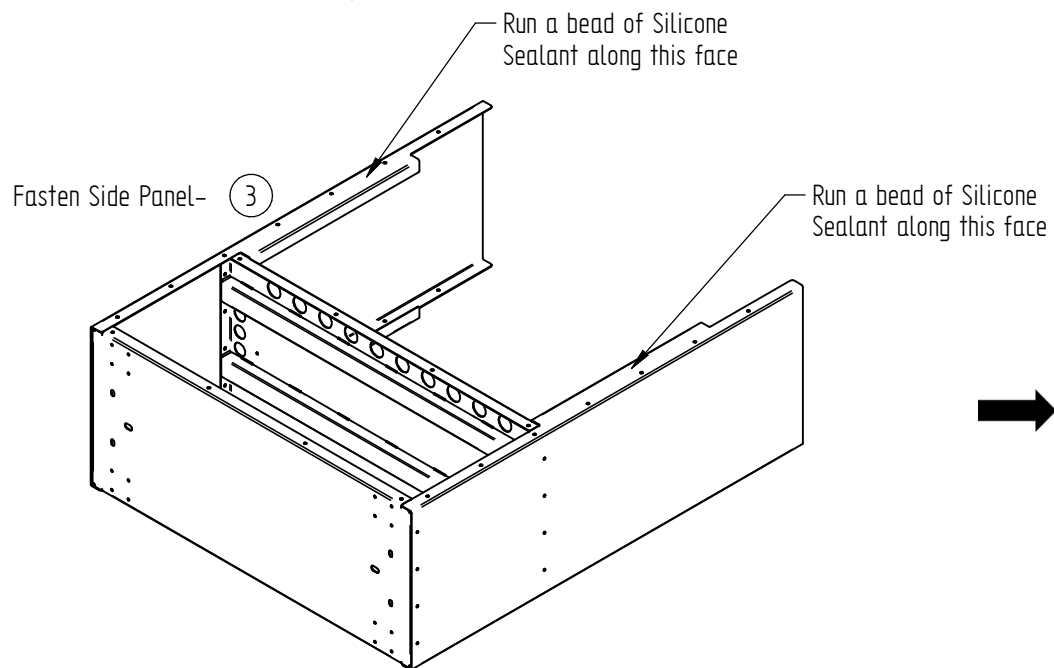

⑤ - Stand Upright

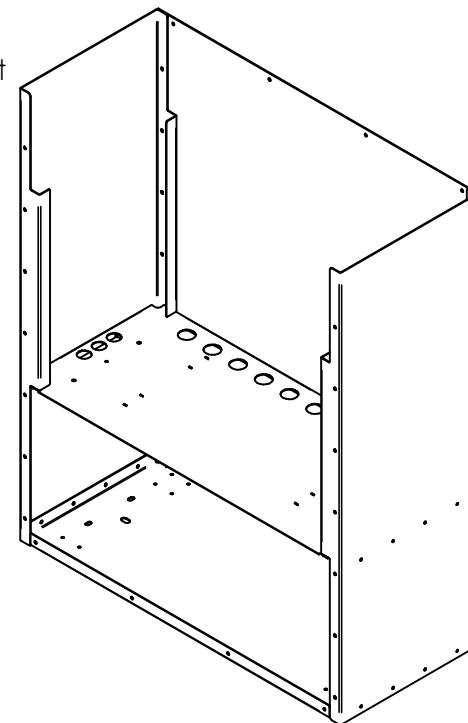

④ - Fasten Rear Panel

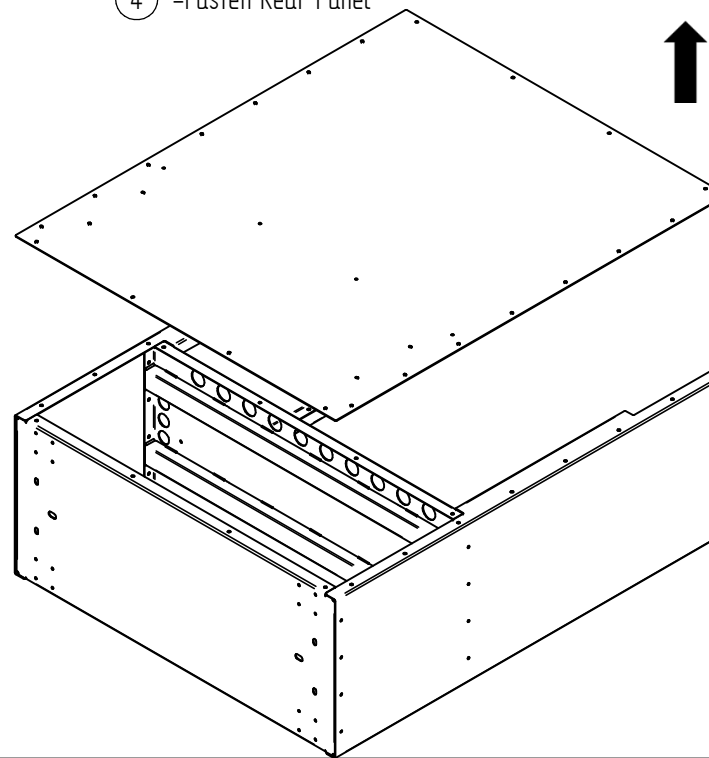

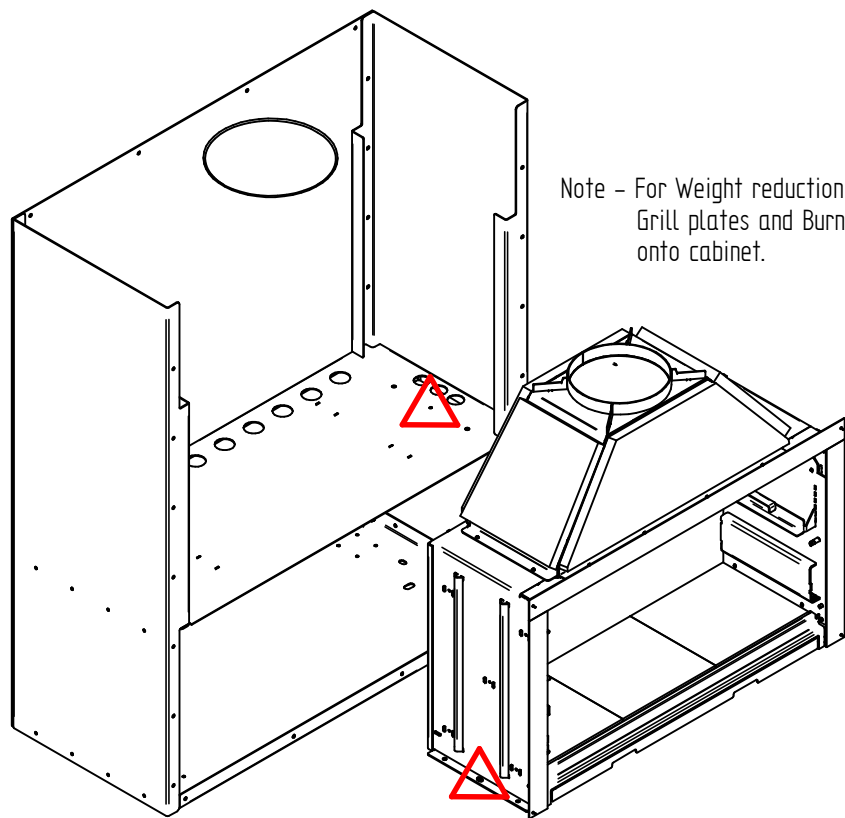

⑥ - Fit Matakana firebox and fasten with M8 bolt, washer and Nut (x2 Places)

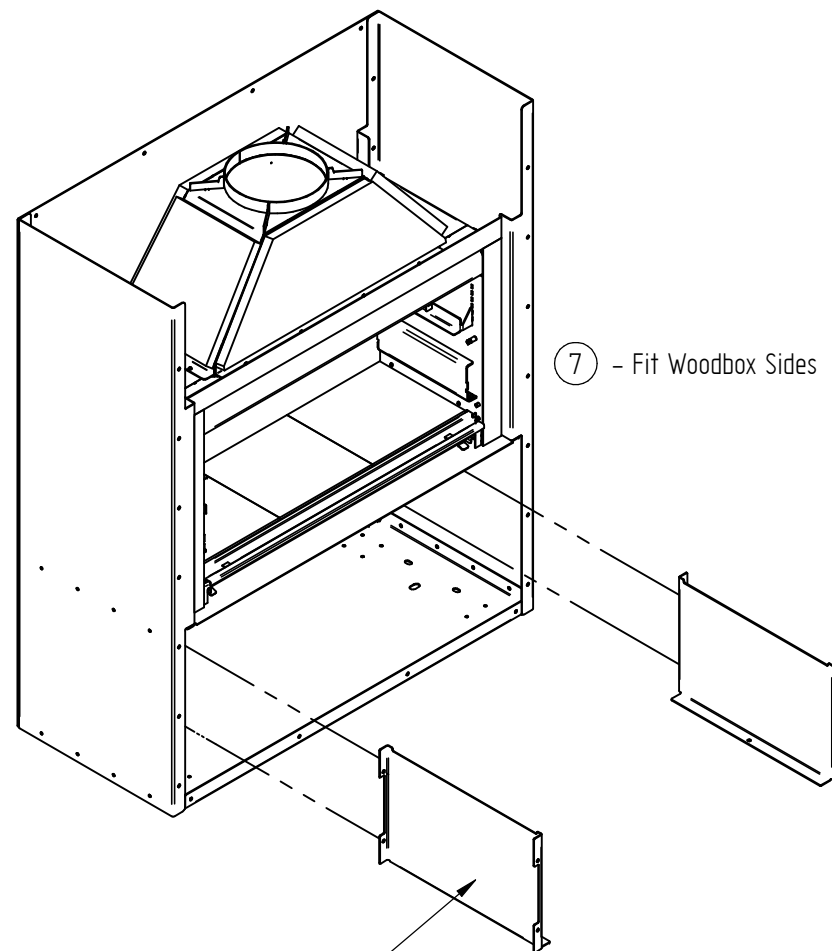

Important - The front edge must overlap the Front Panel by a minimum of 1.5mm.

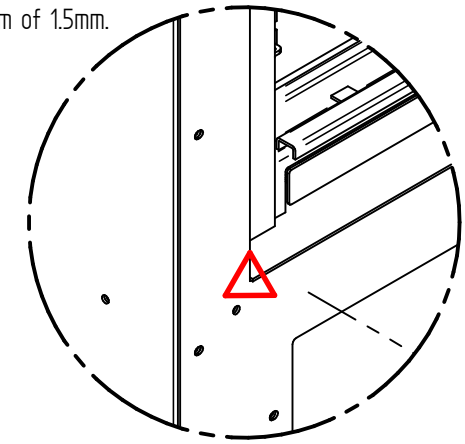

DETAIL A

⑦ - Fit 2x stiffners to front panel

⑧ - Fasten front panel

⑪ - Fit and fasten cap Assembly

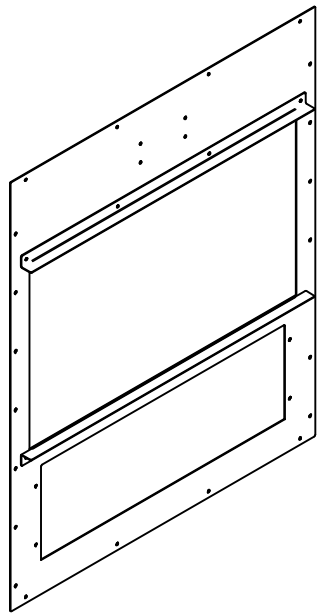

Run a bead of Silicone Sealant along this face

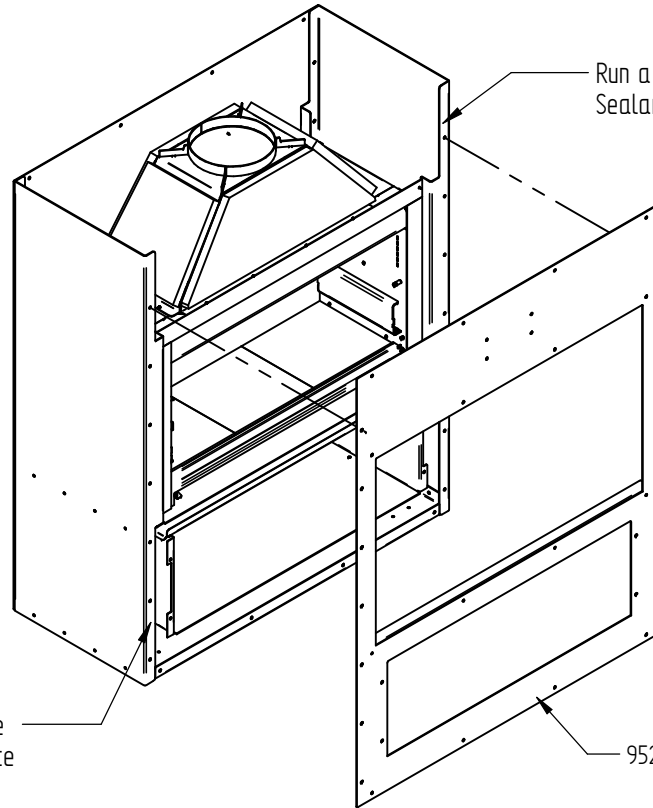

Run a bead of Silicone Sealant along this face



952329-Cap Assembly

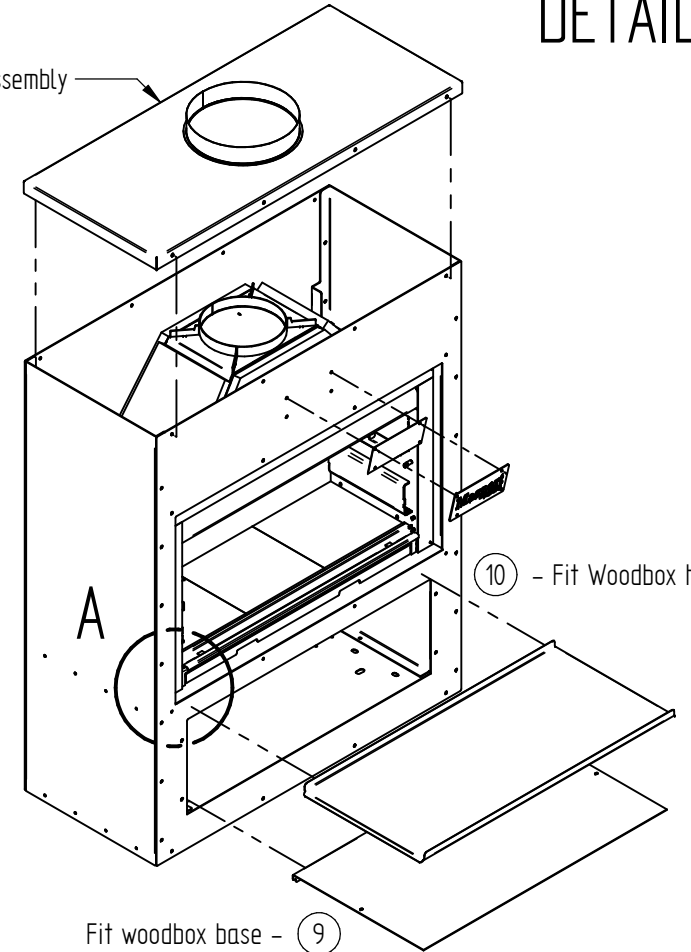

⑩ - Fit Woodbox heatsheild

Fit woodbox base - ⑨

MOUNTING HOLE DETAILS

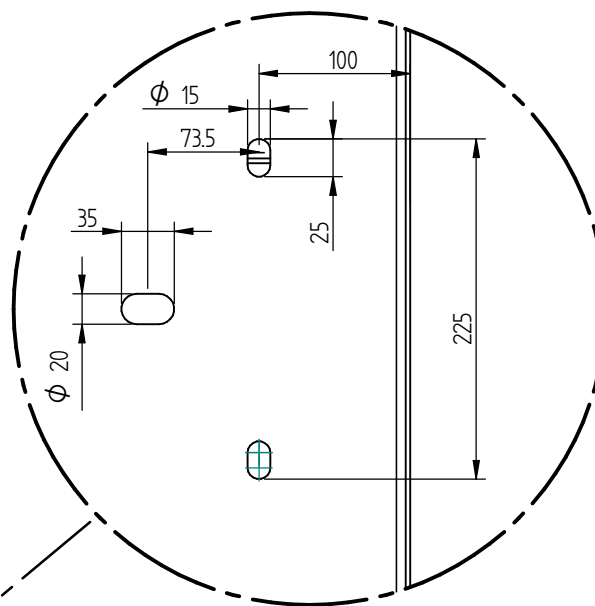
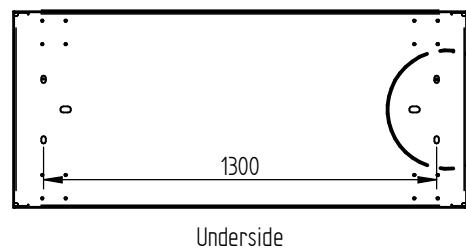
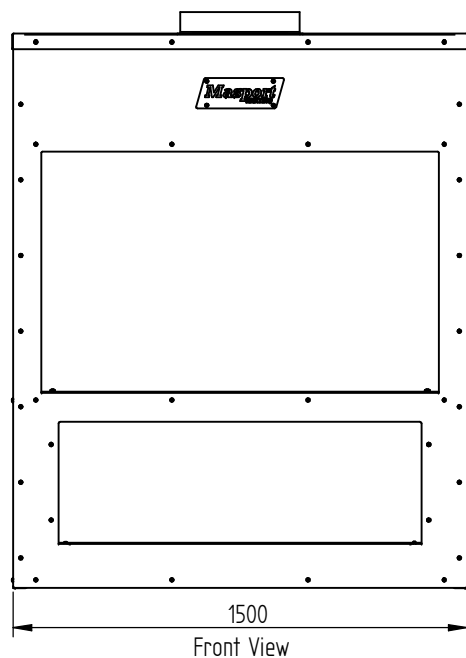
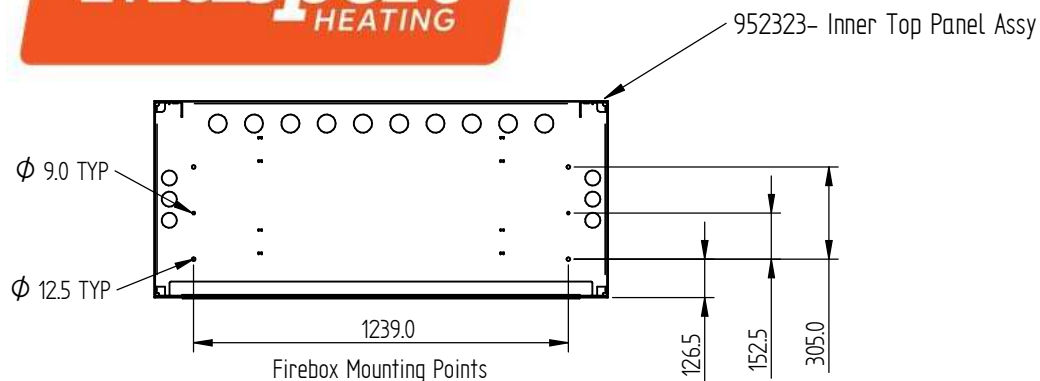

DETAIL F

952326- bottom panel

Note:

- Cabinet and firebox anchor points displayed.
- Cabinet is recommended to be anchored to installation location with suitable fastening or anchoring methods.
- Firebox anchor points to suit Matakana 1200 Outdoor Fire. Additional 9mm holes may be used to drill and tap onto firebox as alternative anchor points.
- Cabinet must be installed such that:
 - A combustible wall shall be no less than 150mm from the rear of the cabinet and shall have no obstruction to air flow.
 - A combustible wall shall be no less than 200mm from the sides of the cabinet and shall have no obstruction to air flow.
 - A combustible wall shall protrude no more than 120mm from the front face of the cabinet and shall have no obstruction to air flow.
 - The Cubbyhole shall have free flowing air in front of the cabinet.
 - The ventilation slot at the rear and front of the Cubbyhole Heat Shield shall not be blocked with excessive storage.
 - Non-combustible enclosures are to follow dimensional requirements for the Matakana 1200 Zero Clearance Cabinet surrounding the Corten Cabinet.
 - Material and dimensional requirements of the surrounding area, including but not limited to ceilings, overhangs, floor protection and heat shielding are to follow requirements of the Matakana 1200 Zero Clearance Cabinet.

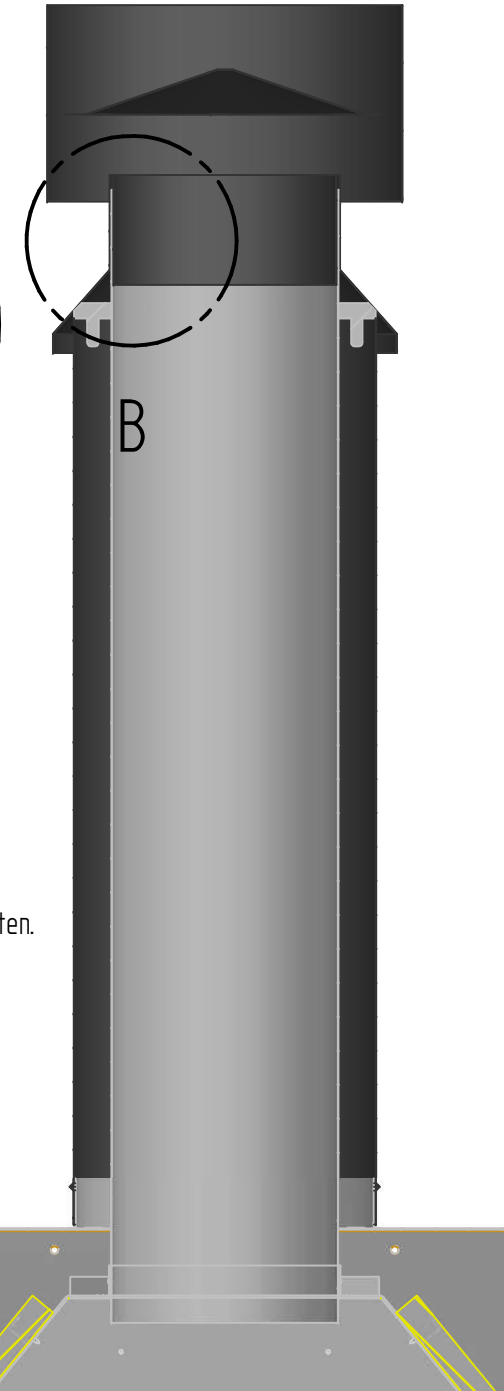
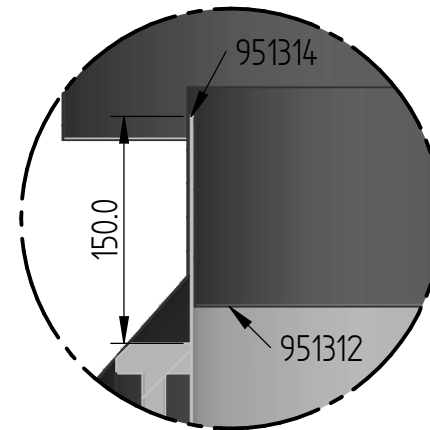
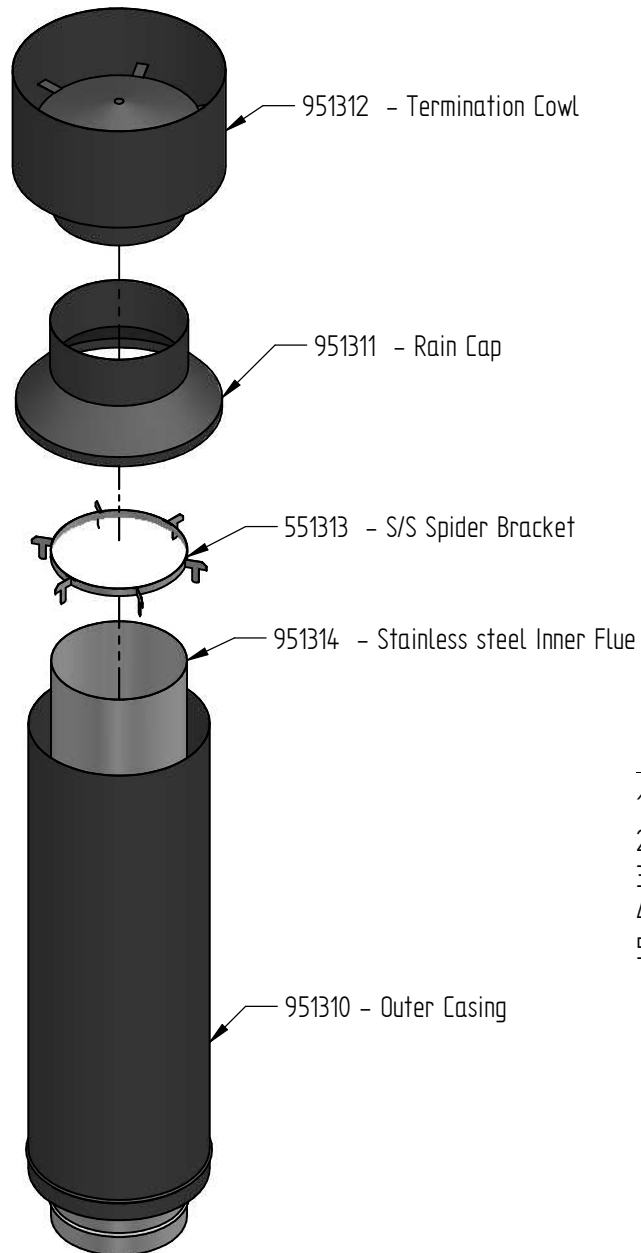

Installation Instructions

1. Place spider bracket (552313) approximately 150mm onto inner flue (951314) and tighten.
2. Fit inner flue to matakana firebox.
3. Fit outer casing (951310) onto the matakana corten cabinet cap (952329)
4. Fit Rain Cap (951311) onto spider Bracket (551313)
5. Fit termination cowl (951312), note that it sits inside the inner Flue (951314)

CLEARANCES

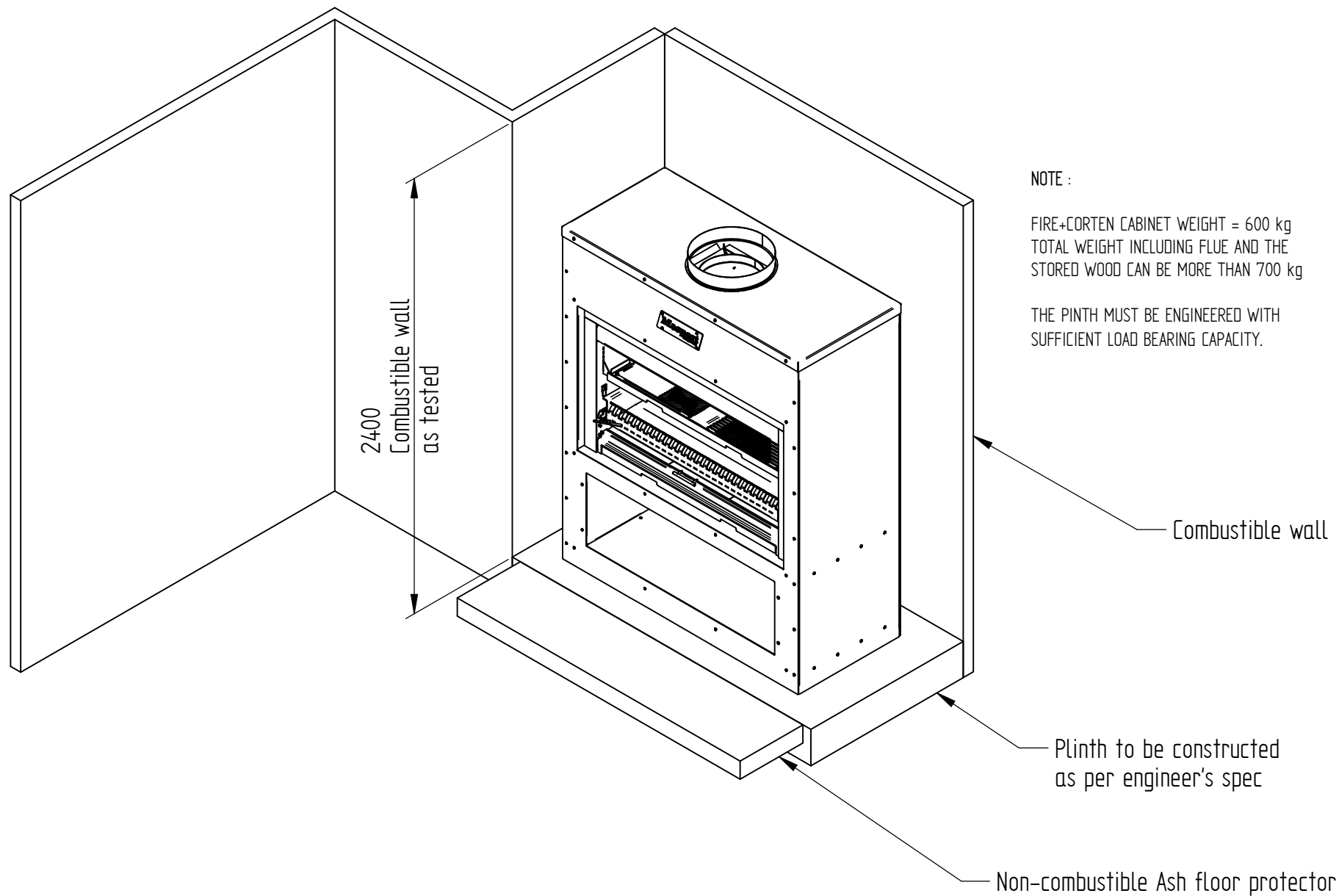

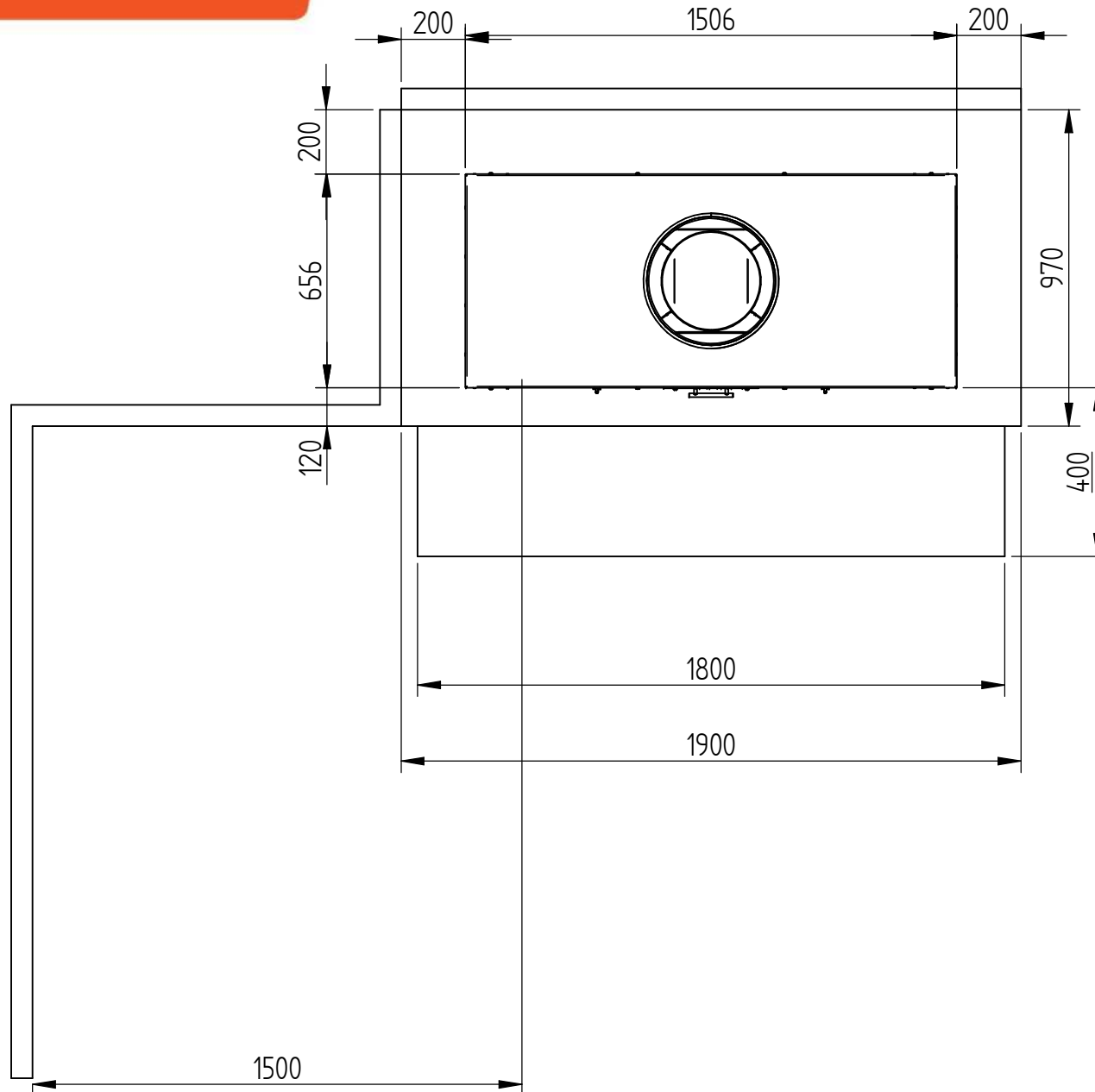

NOTE :

IN THE CLOSE VICINITY OF THE CABINET,
THE SIDE WALL SHOULD NOT PROTRUDE
MORE THAN 120MM FROM THE FRONT
FACE OF THE FIRE.

CORTEN CABINET DIMENSIONS -
1506mm W X 656mm D X 1835mm H

MINIMUM PLINTH SIZE - 1900mm X 970mm WITH
REAR CLEARANCE OF 200MM

ASH FLOOR PROTECTOR - 1800mm X 400mm
IN FRONT OF THE CABINET.

MINIMUM CLEARANCES TO COMBUSTIBLE MATERIAL
REAR OF THE CABINET - 200mm
SIDE OF THE CABINET - 200mm

MINIMUM FLUE REQUIREMENT

1 X 1.5m LONG X 300 DIA ST/ST MAIN FLUE PIPE,
1 X 1.2m LONG X 400 DIA CASING PIPE FOR VENTING
THE CORTEN CABINET, RAIN CAP AND TERMINATION
COWL. FLUE SYSTEM INSTALLATION SHOULD BE
COMPLIANT TO AS/NZS 2918:2001